

A

B

C

D

E

F

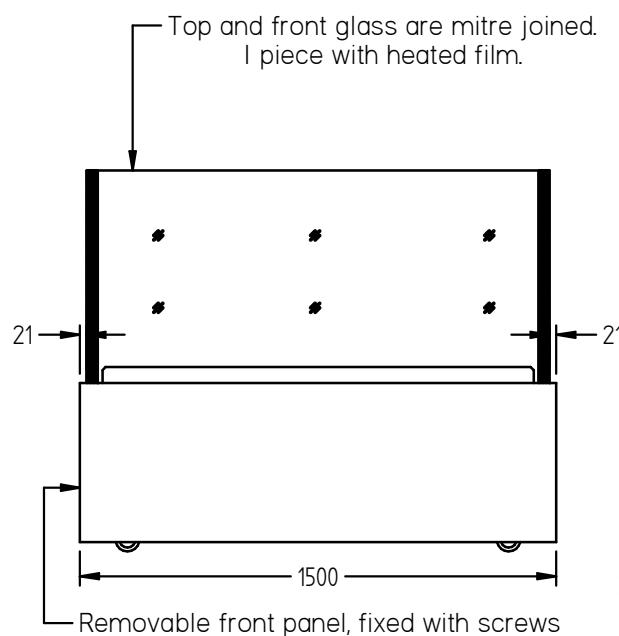

Front View

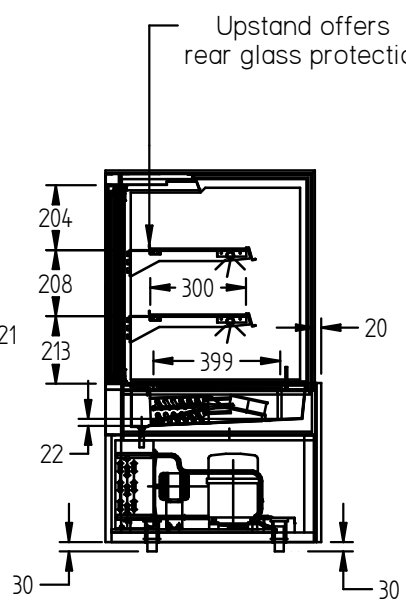

Section View

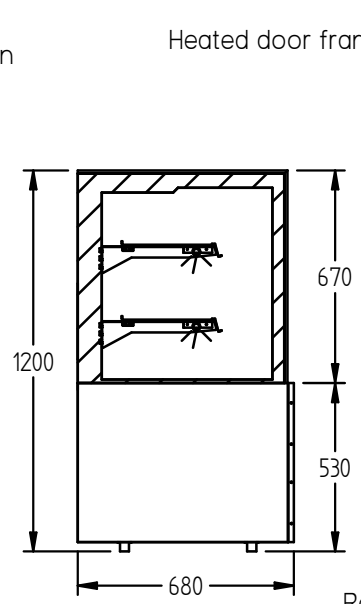

Side View

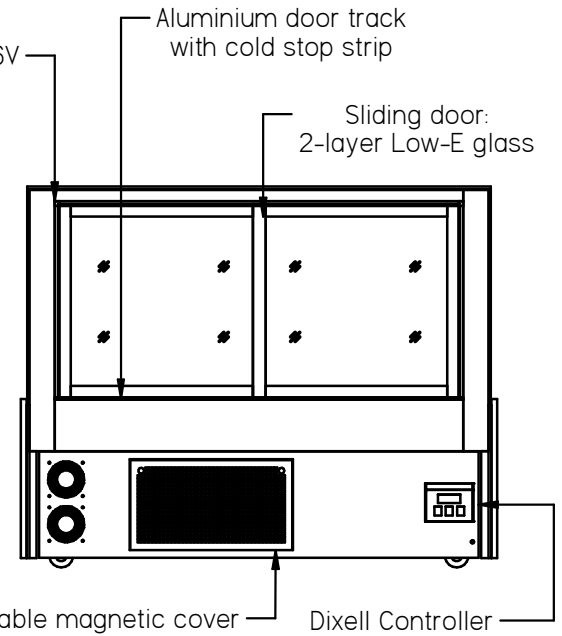

Back View

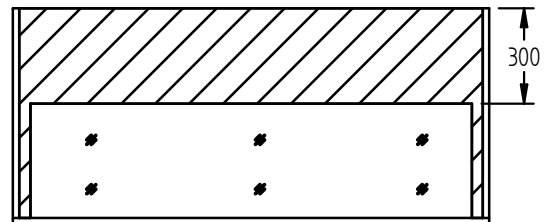

Top View

Technical Data:

1. Dimension: 1500*680*1200Hmm
2. Fan cooling
3. Temp: 2°C - 6°C
4. Base: 430, grain finished S/S, interior: 430 mirror S/S
5. LED light: white color 5000K, 12V
6. Coated glass: black
7. Power: 220V/50HZ, Australia plug
8. Shelving: 1 piece shelf, black coated. Includes LED
9. R134a/R404a refrigerant.

			williams		UNLESS OTHERWISE STATED ALL DIMENSIONS IN MILLIMETERS. GENERAL TOLERANCES:		DRAWN: AJ		MATERIAL: -		Location: -	
			REFRIGERATION AUST. PTY. LTD		LINEAR +/-0.5		DATE: 28/07/23		MODEL: HTG15			
			This drawing and all copies produced remain the property of Williams Refrigeration and must not be copied or distributed by any third party without obtaining authorisation		ANGULAR +/-1°		CHECKED: E.B.		TITLE: CAKE & FOOD DISPLAY		DWG: HTG15	
REV			DESCRIPTION		DATE		BY		DRAFTING STANDARD AS 1100		1500 WIDE, STANDARD VERSION	