

HB2UGHC

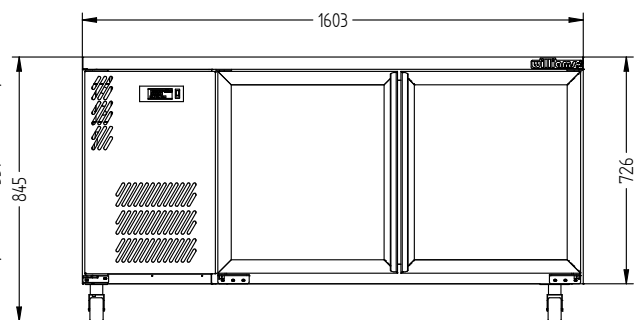

CATEGORY	GENERAL COUNTERS & BACK BARS
RANGE	BORONIA
UNIT	REFRIGERATOR
TYPE	SELF CONTAINED
DOORS	2

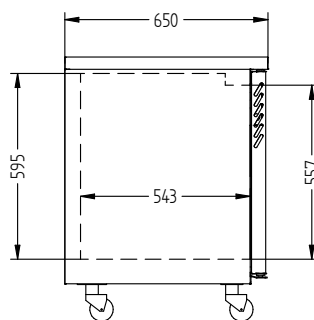
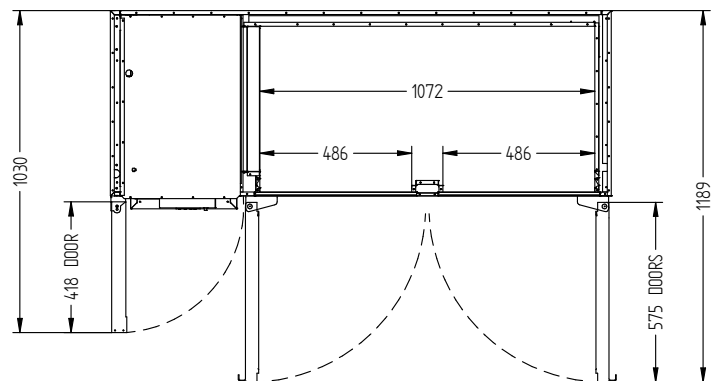

SPECIFICATIONS

CAPACITY LITRES	360
TEMPERATURE	1°C / 4°C
FRONT BREATHING	YES
DIMENSIONS - W X D X H (ON 120 MM H CASTORS) MM	1603 W x 650 D x 845 H
WEIGHT UNPACKED (KG)	130

STANDARD INCLUSIONS ***

DOOR TYPE	Standard: G (Glass Door)
FINISH (INTERIOR AND EXTERIOR EXCLUDING REAR AND UNDER)	B (Black with stainless steel countertop and internal floor) or S (Stainless Steel) interior and exterior excluding rear and under
SHELVES/DOOR (ADJUSTABLE STRIPS AND CLIPS)	2

GAS TYPE

REFRIGERANT	R290
-------------	------

ELECTRICAL

POWER SUPPLY	10 amp
POWER CABLE LENGTH (METRES)	2
RUNNING AMPS	1.6

PERFORMANCE

KWH/24H	2.08
TEMPERATURE CLASS	M1
CLIMATE CLASS	3
AMBIENT RATING	40°C

*** For **OPTIONS** refer to the current Williams Price Guide