

21

Price guide

DESIGN EXCELLENCE : COOL TECHNOLOGY





Cover image: Coogee Pavilion, Sydney. Above: Members of the Williams Australia team, manufacturing cabinets at our Dandenong South (Victoria) factory.

Williams Refrigeration Australia is part of the global Williams Refrigeration Group, which is a major refrigeration division within the international ALI Group Srl. With a reputation for innovation and excellence, Williams Refrigeration is the first choice for quality refrigeration solutions for the foodservice and bakery industries in many countries across the globe.

Williams Refrigeration Australia specialises in designing and manufacturing specifically for Australian conditions and for local market requirements. All products are built for performance, reliability and durability, even in the toughest and most arduous of conditions. With access to global design and development resources, Williams Australia's mission is to employ this global technology in our Australian products, backed up by excellent customer service.

Established in 1986, the modern equipped manufacturing operations based in Dandenong, Victoria is ISO 9001, ISO 14001 and ISO 45001 accredited. The range of Williams foodservice refrigeration equipment available through our extensive Australia wide dealer network includes upright refrigerators and freezers, blast chillers/freezers, gastronorm cabinets, back bars, merchandising cabinets, sandwich bars, pizza preparation counters, under counter storage units and bakery cabinets.

Williams Australia also supplies a wide range of national and international corporate clients with purpose built refrigerated storage solutions tailored to their specific foodservice processing needs.

Our commitment to ongoing product development, excellent customer service and product performance, quality and reliability is second to none. Williams 'right first time' philosophy means that its products provide years of trouble free operation and are easy to service and maintain. But if things do go wrong, they can quickly be repaired with minimal delays and disruption to the working environment.

General uprights	Diamond 7 Pearl 9 Ruby 11 Quartz Star 13 Quartz 15
Foodservice uprights	Garnet 19 Sapphire 21
Foodservice counters	Opal 25 Opal remote 27 Emerald 29 Emerald remote 31
Hydrocarbon	Jade Hydrocarbon 35 Opal Hydrocarbon 37 Meat Aging Refrigerator 39 Aztra Hydrocarbon 41 Vari Temp Drawer 43 Amber Hydrocarbon 45
Bakery	Opal Bakery 49 Garnet Bakery 51 Crystal 53
Preparation counters	Jade Sandwich counter 57 Jade Pizza counter 59 Banksia 61 Thermowell 63
General counters + back bars	Boronia 67 Boronia remote 69 Cameo 71 Cameo remote 73 Glass Chiller 75 Glass Chiller remote 77 Glass Chiller slimline remote 79 Bottle Cooler 81 Wine Cabinet 83
Topaz café range	Topaz Top Mount 87 Topaz Under Counter 89 Topaz Cake & Food display 91 Topaz Milk 93 Topaz Bottle Cooler 95
Blast chiller freezers	Blast Chiller reach in 99 Blast Chiller roll in 700mm 101 Blast Chiller roll in 900mm 104
Foodservice specialised	Mobile Banquet Cart 109 Amber under counter 111 Aztra 113 Jarraah remote 115 Under Broiler Counter 117 Ruby Roll-in 119 Garnet Roll-in 121
General information	Terms + Conditions 125 Warranty + Policy 129 Model Codes explained 130

Minimum Energy Performance Standards (MEPS) explained

An updated MEPS (Minimum Energy Performance standards) regime will start on **1 May 2021**, in accordance with the Greenhouse and Energy Minimum Standards Act (GEMS) requiring commercial fridges and freezers to be tested and then registered on the government GEMS website.

Williams already had many models registered under the previous MEPS requirements, primarily glass door units. The new legislation requires that many other products including solid door units must now be registered. Certain units are currently exempt from requiring registration such as medical, open top, saladette, and blast chiller types.

To register a product, it needs to be fully tested in a test chamber at certain conditions. For Williams products there are two main standards to which units must be tested.

- ISO 23953 – Display (glass door or open units); or
- EN16825 – Professional units (storage).

Laboratory testing results primarily in measuring the electrical energy used. This figure is then used to determine a Star rating, as familiar to Australian consumers.

In anticipation of these changes, Williams has upgraded our range to incorporate many energy efficiency improvements.

These new requirements can be confusing, so please do not hesitate to contact us for further clarification.



Hydrocarbon extraction



ZERO



Williams Refrigeration
have achieved zero
to landfill status



Hydrocarbon charging station

As refrigeration equipment runs 24-7 and 365 days a year its energy consumption is of increasing focus. Through **greenlogic** Williams sets out its criteria for ensuring commitment is given to providing the equipment for today's market—along with assurances as to its professional business standards, accreditation and social responsibility.

Regulation is constantly evolving to further drive environmental compliance and transformation; and through **greenlogic** Williams hope to gain awareness specifying and selecting equipment, recognising Regulation raises the bar for product development and innovation and can offer tax benefits.

Operating in a social and environmentally aware landscape is critical for all our futures and this we see as underscored by third party verification of systems, the business and product itself.

Greenlogic is Williams' commitment to supplying the most energy efficient and sustainable commercial refrigeration in today's market. It's not limited to product design—**greenlogic** covers our plant, manufacturing and management processes too. Our **greenlogic** Customer Support gives advice on making the right decisions for our customers business and the environment.

Williams' commitment to green refrigeration stretches back decades. In the 1980's we were the first manufacturer to develop CFC-free insulation. In the 1990's we developed the first catering refrigeration to use an environment-friendly refrigerant (glycol) with an Ozone Depletion Potential (ODP) of zero. We've pioneered a raft of greener technologies, ranging from energy-saving Smart Controllers to systems using eco-friendly refrigerants.

Greenlogic Products

Our products are 98% recyclable with the remaining 2% treatable for heat recovery.

But to ensure our products are the most sustainable in today's market means considering each and every component. Not just the contribution they make the products over energy efficiency but the impact they have on the environment, and ensuring they have been produced in a sustainable and ethical manner.

Williams follow an Ethical Trading Code and ensure compliance with it by our suppliers— assessing and grading each of them on the environmental management of their product and plant.

Greenlogic Manufacturing

Williams holds ISO14001 Environmental Management certification throughout its global operations for the design, manufacture and servicing of refrigeration products—showing our commitment to reducing its environmental footprint and long term dedication toward decreasing the pollution and waste produced during the manufacturing processes.

We are committed to reducing our environmental footprint:

- All wood pallets are re-used and waste wood recycled.
- Packaging is 100% recyclable, although the bulk of it is reused.
- Shredded office paper is re-used for spare parts packaging.
- Waste and by products are dispatched to specialist waste processors.
- Williams have adopted a zero tolerance refrigerant leak strategy.
- We only use chemicals that are strictly required by our processes.
- Staff are fully trained in Spillage Procedures.
- Investment has been made in energy-saving technologies.
- Energy-saving procedures include function-testing cabinets overnight using off-peak electricity.

Staff are encouraged to think about sustainability at all times—to switch off equipment that's not being used, to avoid unnecessary use of resources such as paper, to order products made from recycled materials, and so on. Through **greenlogic** Williams also offers practical advice on how to save energy, time, resources and money, while creating a better working environment.

Hydrocarbon + Glycol systems

Hydrocarbon is a natural, non-toxic refrigerant that's environmentally safer and heavily reduces energy costs.

Hydrocarbon

Hydrocarbon refrigerant reduces energy consumption by up to 15% due to its excellent thermodynamic properties. It also almost eliminates the environmental impact due to its low Global Warming Potential (GWP) and zero Ozone Depletion Potential (ODP).

The refrigerant charge on all Williams hydrocarbon equipment is below the 150g threshold, enabling it to be placed in any size of room without the need for specific volume calculations thereby eliminating any potentially costly charges by insurance providers.

Refrigerant	GWP	ODP
R290 HC (Hydrocarbon)	3	0
R134a HFC (Hydrofluorocarbon)	1300	0
R404A HFC (Hydrofluorocarbon)	3780	0

Glycol

The award winning glycol system links independently controlled refrigeration equipment on to a 'ring main' with glycol being pumped round the system's pipes, thereby cooling all connected equipment.

- Glycol reduces running costs up to 25% less to run than other systems.
- Glycol saves energy and helps reduce your carbon footprint.
- Glycol is quiet reducing noise levels in the kitchen.
- Glycol is reliable and totally safe for you and the environment. No health risks and very low environmental impact.
- Glycol is more effective providing seemingly instant temperature control.

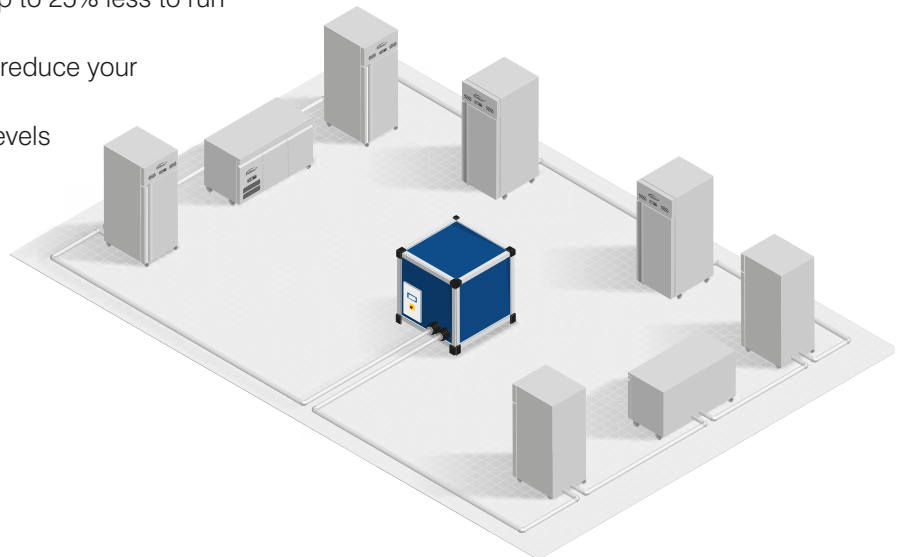



General uprights

Diamond

self contained



Electronic controller



Top mounted

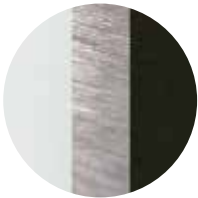

Choice of finishes



LED lighting



10 Amp power

An Australian made cabinet with a choice of a solid or glass door models. A proven performer in many areas of operation.

Available in one door or two door models with a generous 1100 litre capacity in the latter—and your choice of refrigerator or freezer models.



Advantages

- 43°C ambient rating for hard working environments (38°C for glass door freezers)
- CoolSmart electronic controller for energy efficiency and even temperatures
- Top mounted refrigeration system for simple maintenance and easy servicing
- Waste heat recovery vaporiser system—no need for external drain
- Long life and energy efficient 12 volt cool white LED lights
- Threaded castors allow simple leg changeover if required
- Four sets of plastic coated shelves per door
- Peace of mind auto defrost (electric on freezer models)
- Designed and built to international quality standards for reliability and performance
- Triple glazed glass doors as standard on fridge models
- Heated glass doors for reduced condensation and clear view is standard on glass door freezer models. Optional on fridge models.

**STANDARD HINGE ON SINGLE DOOR MODEL
(WHEN FACING FRONT OF UNIT):**

- GLASS DOOR-LHH
- SOLID DOOR-RHH

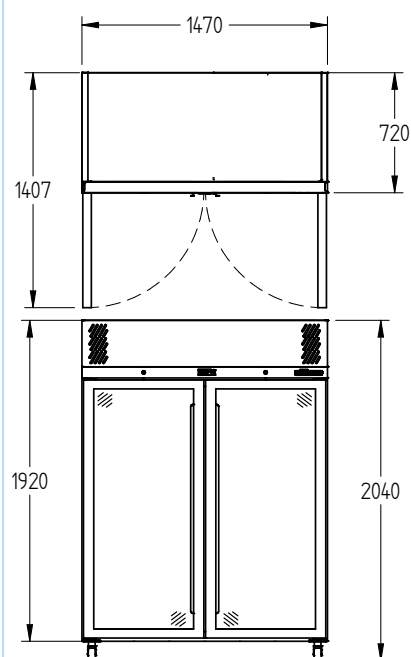
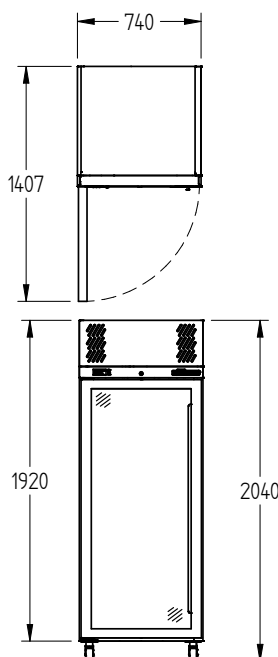
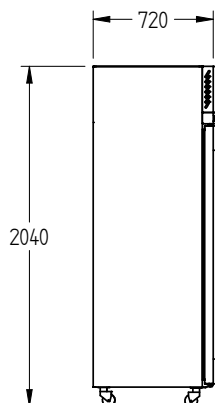

MODEL		1 DOOR		2 DOOR	
H (Refrigerator +1°/+4°C)	White, Glass Door	HD1GW	\$3,656	HD2GW	\$5,771
H (Refrigerator +1°/+4°C)	White, Solid Door	HD1SW	\$3,479	HD2SW	\$5,383
L (Freezer -18°/-22°C)	White, Glass Door	LD1GW	\$6,490	LD2GW	\$8,533
L (Freezer -18°/-22°C)	White, Solid Door	LD1SW	\$5,673	LD2SW	\$7,380
H (Refrigerator +1°/+4°C)	Stainless Steel, Glass Door	HD1GS	\$4,848	HD2GS	\$7,281
H (Refrigerator +1°/+4°C)	Stainless Steel, Solid Door	HD1SS	\$4,509	HD2SS	\$6,790
L (Freezer -18°/-22°C)	Stainless Steel, Glass Door	LD1GS	\$7,703	LD2GS	\$10,301
L (Freezer -18°/-22°C)	Stainless Steel, Solid Door	LD1SS	\$6,884	LD2SS	\$9,350

SPECIFICATIONS

CAPACITY LITRES	520	1100
DIMENSIONS - W X D X H (ON 120MM H CASTORS) MM	740 W x 720 D x 2040 H	1470 W x 720 D x 2040 H
WEIGHT UNPACKED (KG)	160	250

STANDARD INCLUSIONS ***

DOOR TYPE	G (Glass Door), S (Solid Door), Optional: PT (Pass-Through), HD (Half Door)	
FINISH (INTERIOR AND EXTERIOR, EXCLUDES REAR AND UNDER, STAINLESS STEEL INTERNAL FLOOR)	W (White), B (Black), S (Stainless Steel)	
SHELVES/DOOR	4	4

ELECTRICAL

POWER SUPPLY	10 amp	10 amp	
FRIDGE MODELS - GLASS DOORS	RUNNING AMPS	2.8	3.8
FRIDGE MODELS - SOLID DOORS	RUNNING AMPS	2.8	3.2
FREEZER MODELS - GLASS DOORS	RUNNING AMPS	4.7	8.5
FREEZER MODELS - SOLID DOORS	RUNNING AMPS	3.0	3.7

GAS TYPE

REFRIGERANT	FRIDGE MODELS	R134a	R134a
	FREEZER MODELS	R404a	R404a

REFRIGERATION WATTAGES FOR OPTIONAL REMOTE UNITS

FRIDGE MODELS - GLASS DOORS	620 @ -5°C SST	940 @ -5°C SST
FRIDGE MODELS - SOLID DOORS	440 @ -5°C SST	630 @ -5°C SST
FREEZER MODELS - GLASS DOORS	1050 @ -30°C SST	1650 @ -30°C SST
FREEZER MODELS - SOLID DOORS	580 @ -30°C SST	1100 @ -30°C SST

*** For **Diamond OPTIONS** see page 17

Prices do not include GST. Prices and specifications are subject to change without notice.

Pearl

self contained



Electronic controller



Top mounted

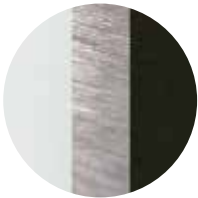

Choice of finishes



LED lighting



10 Amp power

An Australian made cabinet with a choice of a solid or glass door models. A popular and proven performer in many areas of operation.

Available in two door or three door models with a generous 1510 litre capacity in the latter—and your choice of refrigerator or freezer models.



Advantages

- 43°C ambient rating for hard working environments (38°C for glass door freezers)
- CoolSmart electronic controller for energy efficiency and even temperatures
- Top mounted refrigeration system for simple maintenance and easy servicing
- Waste heat recovery vaporiser system—no need for external drain
- Long life and energy efficient 12 volt Cool White LED lights
- Threaded castors allow simple leg changeover if required
- Four sets of plastic coated shelves per door
- Peace of mind auto defrost (electric on freezer models)
- Designed and built to international quality standards for reliability and performance
- Triple glazed glass doors as standard on fridge models
- Optional heated glass doors for reduced condensation and clear view (fridge only) (standard on glass door freezer models)

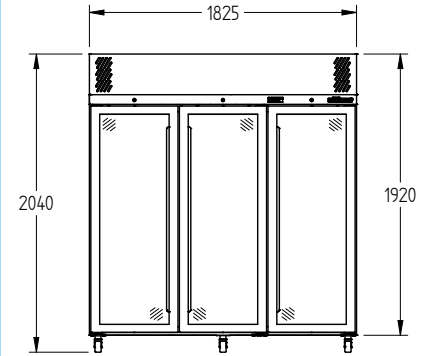
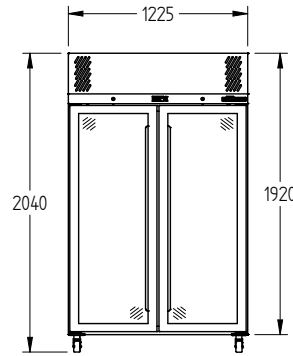
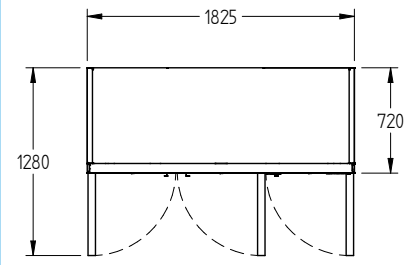
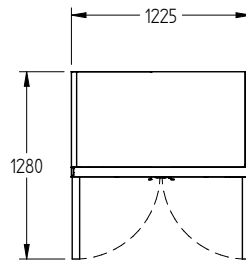
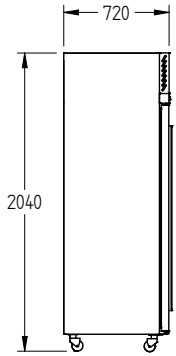

MODEL		2 DOOR		3 DOOR	
H (Refrigerator +1°/+4°C)	White, Glass Door	HP2GW	\$4,550	HP3GW	\$6,733
H (Refrigerator +1°/+4°C)	White, Solid Door	HP2SW	\$4,192	HP3SW	\$6,097
L (Freezer -18°/-22°C)	White, Glass Door	LP2GW	\$8,390	N/A	N/A
L (Freezer -18°/-22°C)	White, Solid Door	LP2SW	\$7,094	LP3SW	\$10,135
H (Refrigerator +1°/+4°C)	Stainless Steel, Glass Door	HP2GS	\$6,500	HP3GS	\$9,562
H (Refrigerator +1°/+4°C)	Stainless Steel, Solid Door	HP2SS	\$5,801	HP3SS	\$8,947
L (Freezer -18°/-22°C)	Stainless Steel, Glass Door	LP2GS	\$9,552	N/A	N/A
L (Freezer -18°/-22°C)	Stainless Steel, Solid Door	LP2SS	\$8,195	LP3SS	\$12,915

SPECIFICATIONS

CAPACITY LITRES	950	1510
DIMENSIONS - W X D X H (ON 120MM H CASTORS) MM	1225 W x 720 D x 2040 H	1825 W x 720 D x 2040 H
WEIGHT UNPACKED (KG)	220	290

STANDARD INCLUSIONS ***

DOOR TYPE	G (Glass Door), S (Solid Door), Optional: PT (Pass-Through) HD (Half Door)	
FINISH (INTERIOR AND EXTERIOR, EXCLUDES REAR AND UNDER, STAINLESS STEEL INTERNAL FLOOR)	W (White), B (Black), S (Stainless Steel)	
SHELVES/DOOR	4	4

ELECTRICAL

POWER SUPPLY	10 amp	10 amp	
FRIDGE MODELS - GLASS DOORS	RUNNING AMPS	3.8	5.4
FRIDGE MODELS - SOLID DOORS	RUNNING AMPS	3.2	3.8
FREEZER MODELS - GLASS DOORS	RUNNING AMPS	7.5	N/A
FREEZER MODELS - SOLID DOORS	RUNNING AMPS	3.7	6.1

GAS TYPE

REFRIGERANT	FRIDGE MODELS	R134a	R134a
	FREEZER MODELS	R404a	R404a

REFRIGERATION WATTAGES FOR OPTIONAL REMOTE UNITS

FRIDGE MODELS - GLASS DOORS	850 @ -5°C SST	1120 @ -5°C SST
FRIDGE MODELS - SOLID DOORS	580 @ -5°C SST	700 @ -5°C SST
FREEZER MODELS - GLASS DOORS	1480 @ -30°C SST	N/A
FREEZER MODELS - SOLID DOORS	950 @ -30°C SST	1550 @ -30°C SST

*** For **Pearl OPTIONS** see page 17

Prices do not include GST. Prices and specifications are subject to change without notice.

Ruby

self contained



Electronic controller



Top mounted

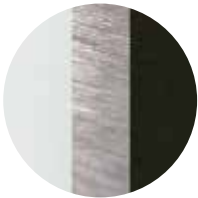

Choice of finishes



LED lighting



10 Amp power

An Australian made cabinet with a choice of a two or three door model and optional glass door types. A proven performer in many areas of operation.

The Ruby has a generous 1160 Litre capacity in the three door and your choice of refrigerator or freezer.



Advantages

- 43°C ambient rating for hard working environments
- CoolSmart electronic controller for energy efficiency and even temperatures
- Top mounted refrigeration system for simple maintenance and easy servicing
- Waste heat recovery vaporiser system—no need for external drain
- Long life and energy efficient 12 volt cool white LED lights
- Threaded castors allow simple leg changeover if required
- Four sets of plastic coated shelves per door
- Peace of mind auto defrost (electric on freezer models)
- Designed and built to international quality standards for reliability and performance
- Triple glazed glass doors as standard on fridge models
- Optional heated glass doors for reduced condensation and clear view (fridge only)

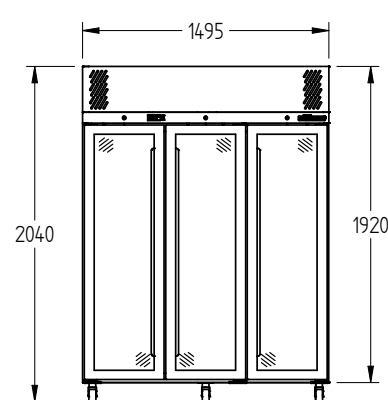
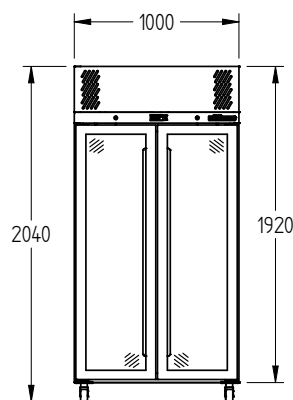
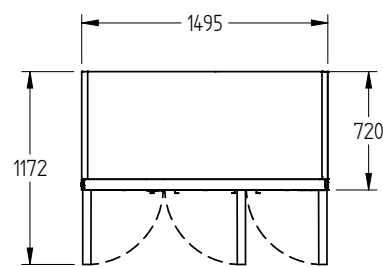
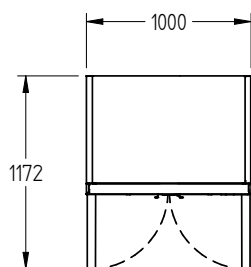
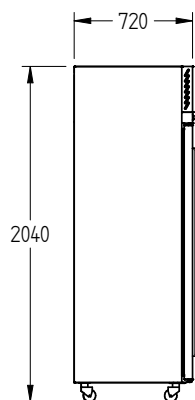

MODEL		2 DOOR		3 DOOR	
H (Refrigerator +1°/+4°C)	White, Glass Door	HR2GW	\$4,065	HR3GW	\$5,857
H (Refrigerator +1°/+4°C)	White, Solid Door	HR2SW	\$3,830	HR3SW	\$5,445
L (Freezer -18°/-22°C)	White, Solid Door	LR2SW	\$6,205	LR3SW	\$7,812
H (Refrigerator +1°/+4°C)	Stainless Steel, Glass Door	HR2GS	\$5,679	HR3GS	\$7,778
H (Refrigerator +1°/+4°C)	Stainless Steel, Solid Door	HR2SS	\$5,399	HR3SS	\$7,343
L (Freezer -18°/-22°C)	Stainless Steel, Solid Door	LR2SS	\$7,875	LR3SS	\$9,706

SPECIFICATIONS

CAPACITY LITRES	750	1160
DIMENSIONS - W X D X H (ON 120MM H CASTORS) MM	1000 W x 720 D x 2040 H	1495 W x 720 D x 2040 H
WEIGHT UNPACKED (KG)	200	250

STANDARD INCLUSIONS ***

DOOR TYPE	G (Glass Door), S (Solid Door), Optional: PT (Pass-Through)	
FINISH (INTERIOR AND EXTERIOR, EXCLUDES REAR AND UNDER, STAINLESS STEEL INTERNAL FLOOR)	W (White), B (Black) S (Stainless Steel)	
SHELVES/DOOR	4	4

ELECTRICAL

POWER SUPPLY	10 amp	10 amp	
FRIDGE MODELS - GLASS DOORS	RUNNING AMPS	3.0	4.0
FRIDGE MODELS - SOLID DOORS	RUNNING AMPS	2.7	3.3
FREEZER MODELS - SOLID DOORS	RUNNING AMPS	2.8	3.7

GAS TYPE

REFRIGERANT	FRIDGE MODELS	R134a	R134a
	FREEZER MODELS	R404a	R404a

REFRIGERATION WATTAGES FOR OPTIONAL REMOTE UNITS

FRIDGE MODELS - GLASS DOORS	760 @ -5°C SST	900 @ -5°C SST
FRIDGE MODELS - SOLID DOORS	530 @ -5°C SST	660 @ -5°C SST
FREEZER MODELS - SOLID DOORS	710 @ -30°C SST	960 @ -30°C SST

*** For **Ruby OPTIONS** see page 17

Prices do not include GST. Prices and specifications are subject to change without notice.

Quartz Star

self contained



Electronic controller



Bottom mounted

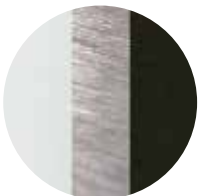

Choice of finishes



LED lighting



10 Amp power

An Australian made cabinet with a choice of a one, two and three door models and optional glass door types.

A proven performer in many areas of operation this range comes with energy efficient triple glazed doors as a standard.

The refrigeration cassette system is removable for simple maintenance and servicing, giving this model and all round tick of approval.



Advantages

- 43°C ambient rating for hard working environments (38°C for the HQS3GD Model)
- CoolSmart electronic controller for energy efficiency and even temperatures
- Bottom mounted removable refrigeration cassette system for simple maintenance and easy servicing
- Warm waste air from the evaporator blows up the front of the glass to help reduce condensation
- Waste heat recovery vaporiser system—no need for external drain
- Long life and energy efficient 12 volt cool white LED lights
- Threaded castors allow simple leg changeover if required
- Four sets of plastic coated shelves per door
- Peace of mind auto defrost
- Designed and built to international quality standards for reliability and performance
- Triple glazed glass doors are standard
- Optional heated glass doors for reduced condensation and clear view

**STANDARD HINGE ON SINGLE DOOR MODEL
(WHEN FACING FRONT OF UNIT):**

- GLASS DOOR-LHH
- SOLID DOOR-RHH

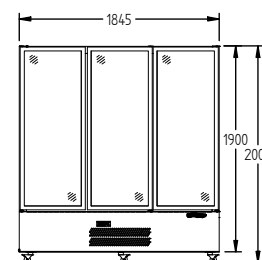
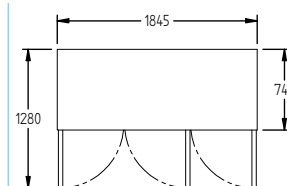
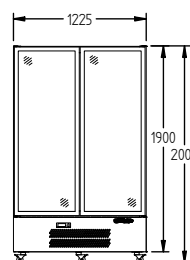
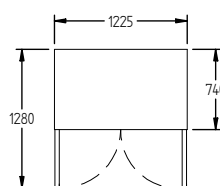
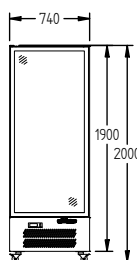
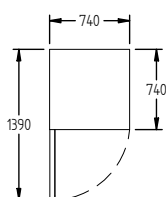
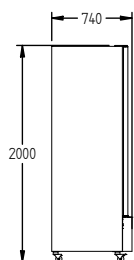

MODEL		1 DOOR		2 DOOR		3 DOOR	
H (Refrigerator +1°/+4°C)	White, Glass Door	HQS1GW	\$3,656	HQS2GW	\$4,550	HQS3GW	\$6,732
H (Refrigerator +1°/+4°C)	White, Solid Door	HQS1SW	\$3,479	HQS2SW	\$4,192	HQS3SW	\$6,097
H (Refrigerator +1°/+4°C)	Stainless Steel, Glass Door	HQS1GS	\$4,848	HQS2GS	\$6,500	HQS3GS	\$9,562
H (Refrigerator +1°/+4°C)	Stainless Steel, Solid Door	HQS1SS	\$4,509	HQS2SS	\$5,801	HQS3SS	\$8,947

SPECIFICATIONS

CAPACITY LITRES	500	900	1500
DIMENSIONS - W X D X H (ON CASTORS) MM	740 W x 740 D x 2000 H	1225 W x 740 D x 2000 H	1845 W x 745 D x 2000 H
WEIGHT UNPACKED (KG)	160	230	300

STANDARD INCLUSIONS ***

DOOR TYPE	G (Glass Door), S (Solid Door), Optional: PT (Pass-Through)		
FINISH (INTERIOR AND EXTERIOR, EXCLUDES REAR AND UNDER, STAINLESS STEEL INTERNAL FLOOR)	W (White), B (Black), S (Stainless Steel)		
SHELVES/DOOR	4	4	4

ELECTRICAL

POWER SUPPLY	10 amp	10 amp	10 amp	
FRIDGE MODELS - GLASS DOORS	RUNNING AMPS	2.6	3.2	3.8
FRIDGE MODELS - SOLID DOORS	RUNNING AMPS	2.5	3.2	3.8

GAS TYPE

REFRIGERANT	FRIDGE MODELS	R134a	R134a	R134a
--------------------	----------------------	-------	-------	-------

REFRIGERATION WATTAGES FOR OPTIONAL REMOTE UNITS

FRIDGE MODELS - GLASS DOORS	620 @ -5°C SST	760 @ -5°C SST	1120 @ -5°C SST
FRIDGE MODELS - SOLID DOORS	440 @ -5°C SST	580 @ -5°C SST	700 @ -5°C SST

*** For **Quartz OPTIONS** see page 17

Prices do not include GST. Prices and specifications are subject to change without notice.

Quartz

self contained



Electronic controller



Bottom mounted



Verticle handles



LED lighting



10 Amp power

An Australian made cabinet with a choice of a one or two door model and option of glass door and solid door types. A proven performer in many areas of operation. A generous 670 Litre capacity in the two door model and all in just 1000 mm wide.



Advantages

- 43°C ambient rating for hard working environments
- CoolSmart electronic controller for energy efficiency and even temperatures
- Easy clean coved internal liner
- Bottom mounted refrigeration system
- Waste heat recovery vaporiser system—no need for external drain
- Long life and energy efficient 12 volt cool white LED lights
- Threaded castors allow simple leg changeover if required
- Four sets of plastic coated shelves per door
- Peace of mind auto defrost
- Designed and built to international quality standards for reliability and performance
- Triple glazed glass doors are standard
- Optional heated glass doors for reduced condensation and clear view

**STANDARD HINGE ON SINGLE DOOR MODEL
(WHEN FACING FRONT OF UNIT):**

- GLASS DOOR-LHH
- SOLID DOOR-RHH

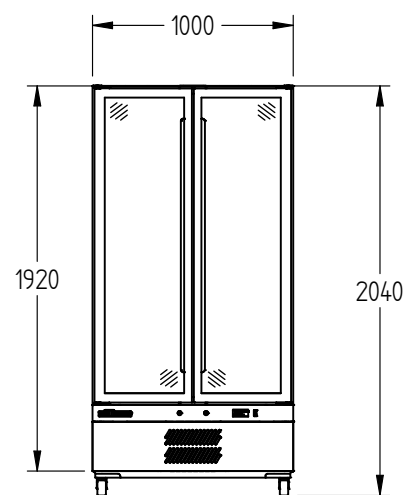
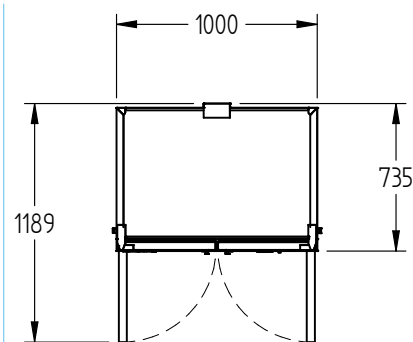
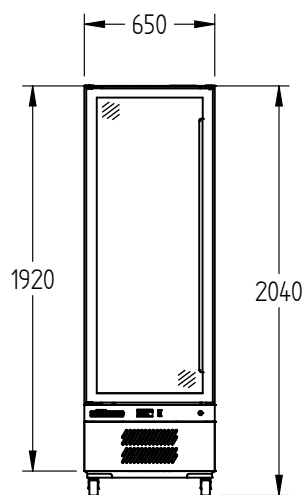
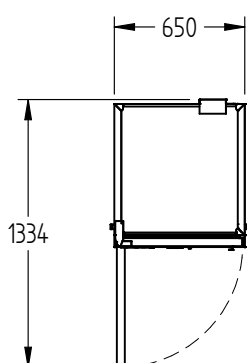
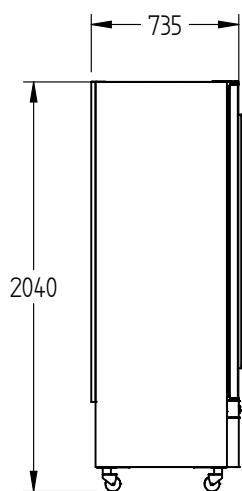

MODEL		1 DOOR		2 DOOR	
H (Refrigerator +1°/+4°C)	White, Glass Door	HQ1GW	\$3,320	HQ2GW	\$3,716
H (Refrigerator +1°/+4°C)	White, Solid Door	HQ1SW	\$3,163	HQ2SW	\$3,597
H (Refrigerator +1°/+4°C)	Stainless Steel, Glass Door	HQ1GS	\$4,307	HQ2GS	\$5,809
H (Refrigerator +1°/+4°C)	Stainless Steel, Solid Door	HQ1SS	\$4,150	HQ2SS	\$5,635

SPECIFICATIONS

CAPACITY LITRES	400	670
DIMENSIONS - W X D X H (ON 120MM H CASTORS) MM	650 W x 735 D x 2040 H	1000 W x 735 D x 2040 H
WEIGHT UNPACKED (KG)	150	200

STANDARD INCLUSIONS ***

DOOR TYPE	G (Glass Door), S (Solid Door)	
FINISH (INTERIOR AND EXTERIOR, EXCLUDES REAR AND UNDER, STAINLESS STEEL INTERNAL FLOOR)	W (White), B (Black), S (Stainless Steel)	
SHELVES/DOOR	4	4

ELECTRICAL

POWER SUPPLY	10 amp	10 amp	
FRIDGE MODELS - GLASS DOORS	RUNNING AMPS	3.0	3.3
FRIDGE MODELS - SOLID DOORS	RUNNING AMPS	3.0	3.3

GAS TYPE

REFRIGERANT	FRIDGE MODELS	R134a	R134a
--------------------	----------------------	-------	-------

REFRIGERATION WATTAGES FOR OPTIONAL REMOTE UNITS

FRIDGE MODELS - GLASS DOORS	500 @ -5°C SST	720 @ -5°C SST
FRIDGE MODELS - SOLID DOORS	400 @ -5°C SST	600 @ -5°C SST

*** For Quartz OPTIONS see page 17

Prices do not include GST. Prices and specifications are subject to change without notice.

Options

General uprights

Quartz Star
Quartz

Diamond
Pearl
Ruby



Choice of colour options



LED lighting



Powder-coated finish



Heated glass doors



Cylindrical locks



Pass-through



Locking tabs



Stainless steel shelves

OPTIONS	DIAMOND		PEARL		RUBY		QUARTZ STAR			QUARTZ	
	D1	D2	P2	P3	R2	R3	QS1	QS2	QS3	Q1	Q2
	1 DOOR	2 DOOR	2 DOOR	3 DOOR	2 DOOR	3 DOOR	1 DOOR	2 DOOR	3 DOOR	1 DOOR	2 DOOR
430 grade stainless steel rear & under	\$295	\$590	\$590	\$885	\$590	\$885	\$295	\$590	\$885	\$295	\$590
4622 stainless steel interior & exterior excluding rear and under	\$450	\$900	\$900	\$1,350	\$900	\$1,350	\$450	\$900	\$1,350	\$450	\$900
4622 stainless steel rear & under	\$355	\$710	\$710	\$1,065	\$710	\$1,065	\$355	\$710	\$1,065	\$355	\$710
430 grade stainless exterior 4622 stainless interior	\$295	\$590	\$590	\$885	\$590	\$885	\$295	\$590	\$885	\$295	\$590
Colour finish other than black and white	\$170	\$340	\$340	\$510	\$340	\$510	\$170	\$340	\$510	\$170	\$340
Powder-coat exterior only, black or white excluding rear and under	\$770	\$1,540	\$1,540	\$1,955	\$1,540	\$1,955	\$770	\$1,540	\$1,955	\$770	\$1,540
Cylindrical locks	\$135	\$270	\$270	\$405	\$270	\$405	\$135	\$270	\$405	\$135	\$270
Locking tabs	\$30	\$60	\$60	\$90	\$60	\$90	\$30	\$60	\$90	\$30	\$60
Light to solid doors	\$85	\$175	\$175	\$350	\$175	\$350	\$85	\$175	\$350	\$85	\$175
Extra plastic coated shelf with clips	\$57	\$114	\$114	\$171	\$114	\$171	\$57	\$114	\$171	\$57	\$114
Punched stainless steel shelf upgrade (each)	\$195	\$390	\$390	\$585	\$390	\$585	\$195	\$390	\$585	\$195	\$390
Lower castors (2005 high, QS 1965)	\$100	\$150	\$150	\$150	\$150	\$150	\$100	\$150	\$150	\$100	\$150
Adjustable legs (150 mm high)	\$60	\$90	\$60	\$90	\$60	\$90	\$60	\$90	\$90	\$60	\$60
DOOR OPTIONS (refrigerator only)											
Triple glazed heated glass doors	\$685	\$1,370	\$1,370	\$2,055	\$1,370	\$2,055	\$685	\$1,370	\$2,055	\$685	\$1,370
PASS-THROUGH (refrigerator only)											
Solid doors	\$1,185	\$1,595	\$1,595	\$2,370	\$1,595	\$2,370	\$1,185	\$1,595	N/A	N/A	N/A
Triple glazed Argon doors to both sides	\$1,775	\$2,380	\$2,380	\$3,525	\$2,380	\$3,525	N/A	N/A	N/A	N/A	N/A
Triple glazed heated doors to both sides	\$2,555	\$3,950	\$3,950	\$5,925	\$3,950	\$5,925	N/A	N/A	N/A	N/A	N/A
Cylindrical locks	\$270	\$540	\$540	\$810	\$540	\$810	\$270	\$540	N/A	N/A	N/A
REMOTE APPLICATION (condensing unit excluded)											
Refrigerator (deduct)	\$265	\$330	\$330	\$490	\$330	\$490	\$265	\$330	\$490	\$265	\$330
Freezer (deduct)	\$365	\$480	\$480	\$535	\$480	\$535	N/A	N/A	N/A	N/A	N/A

NOTES

- Optional adjustable legs (supplied loose) in lieu of castors adds 30 mm to overall height (QS +50 mm)
- Standard hinge on single door model: GD-LHH, SD-RHH when facing front of unit
- Optional door hang on single door (must be advised at time of order, new build only)
- Glass door freezer models include triple glazed heated glass doors as standard
- Optional doors may lower ambient rating
- Pass-through model may increase cabinet depth by 50 mm
- Light (with on/off switch) as standard on glass door models only
- SS & PC material options above in addition to base S unit prices
- Gas type: Refrigerator—134a: Freezer—404a: Optional Remote (refrigerator and freezer) 404a

A stainless steel foodservice upright refrigerator is the central focus of the image. It features a digital display on the upper left side and a 'williams' logo on the upper right. The refrigerator is set against a light-colored tiled wall. In the foreground, a red mushroom-shaped object is visible on a counter to the left. The overall scene is dimly lit, with a blue vertical bar on the right side of the frame.

Foodservice uprights

Garnet

self contained



Electronic controller



Top mounted



GN pan compatible



Cylindrical locks



10 Amp power

A high performance cabinet with a choice of a one or two door Gastronorm models and various options. A proven performer in many areas of operation.

A generous 1270 litre capacity in the two door and your choice of refrigerator or freezer.



Advantages

- 43°C ambient rating for hard working environments
- CoolSmart electronic controller for energy efficiency and even temperatures
- Easy clean covered internal liner
- Top mounted refrigeration system for simple maintenance and easy servicing
- Waste heat recovery vaporiser system—no need for external drain
- Threaded castors allow simple leg changeover if required
- Four 2/1 Gn plastic coated shelves/door
- Accommodates 2/1 Gastronorm pans on shelves or dedicated anti tilt tray slides
- Full length door handle
- Cylindrical locks fitted as standard
- Peace of mind auto defrost (electric on freezer models)
- Designed and built to international quality standards for reliability and performance
- 75 mm spacing between slides

**STANDARD HINGE ON SINGLE DOOR MODEL
(WHEN FACING FRONT OF UNIT):**
• RIGHT HAND HINGED

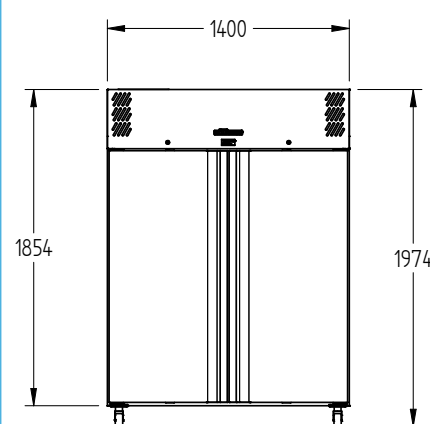
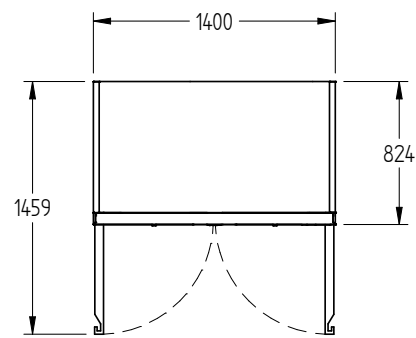
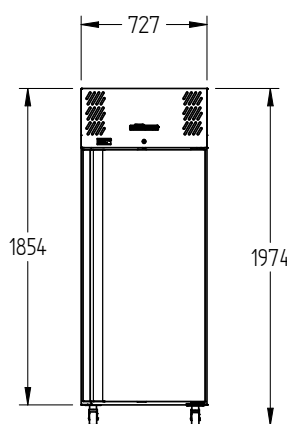
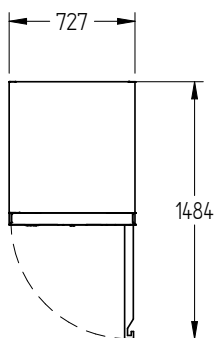
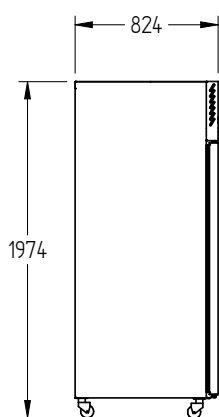

MODEL	1 DOOR		2 DOOR	
H (REFRIGERATOR +1°/+4°C)	HG1SS	\$5,415	HG2SS	\$7,284
L (FREEZER -18°/-22°C)	LG1SS	\$6,869	LG2SS	\$9,369

SPECIFICATIONS

CAPACITY LITRES	610	1270
DIMENSIONS - W X D X H (ON CASTORS) MM	727 W x 824 D x 1974 H	1400 W x 824 D x 1974 H
WEIGHT UNPACKED (KG)	170	220

STANDARD INCLUSIONS ***

DOOR TYPE	Standard: S (Solid Door) Optional: HD (Half Door) PT (Pass Through)	
FINISH (INTERIOR AND EXTERIOR EXCLUDING REAR AND UNDER)	S (Stainless Steel)	
SHELVES/DOOR	4	4

ELECTRICAL

POWER SUPPLY	10 amp	10 amp	
FRIDGE MODELS	RUNNING AMPS	2.8	3.8
FREEZER MODELS	RUNNING AMPS	4.5	5.2

GAS TYPE

REFRIGERANT	FRIDGE MODELS	R134a	R134a
	FREEZER MODELS	R404a	R404a

REFRIGERATION WATTAGES FOR OPTIONAL REMOTE UNITS

FRIDGE MODELS - SOLID DOORS	470 @ -5°C SST	670 @ -5°C SST
FREEZER MODELS - SOLID DOORS	630 @ -30°C SST	900 @ -30°C SST

*** For **Garnet OPTIONS** see page 23

Prices do not include GST. Prices and specifications are subject to change without notice.

Sapphire

self contained



Electronic controller



Top mounted



GN pan compatible



Cylindrical locks



10 Amp power

A high performance cabinet with a choice of a one or two door Gastronorm models and various options. A proven performer in many areas of operation.

A generous 1270 litre capacity in the two door and your choice of refrigerator or freezer.



Advantages

- 43°C ambient rating for hard working environments
- CoolSmart electronic controller for energy efficiency and even temperatures
- Easy clean coved internal liner
- Top mounted refrigeration system for simple maintenance and easy servicing
- Waste heat recovery vaporiser system—no need for external drain
- Threaded castors allow simple leg changeover if required
- Four 2/1 Gn plastic coated shelves/door
- Accommodates 2/1 Gastronorm pans on shelves or dedicated anti-tilt tray slides
- Full length door handle
- Peace of mind auto defrost (electric on freezer models)
- Designed and built to international quality standards for reliability and performance
- 75 mm spacing between slides

**STANDARD HINGE ON SINGLE DOOR MODEL
(WHEN FACING FRONT OF UNIT):**

- RIGHT HAND HINGED

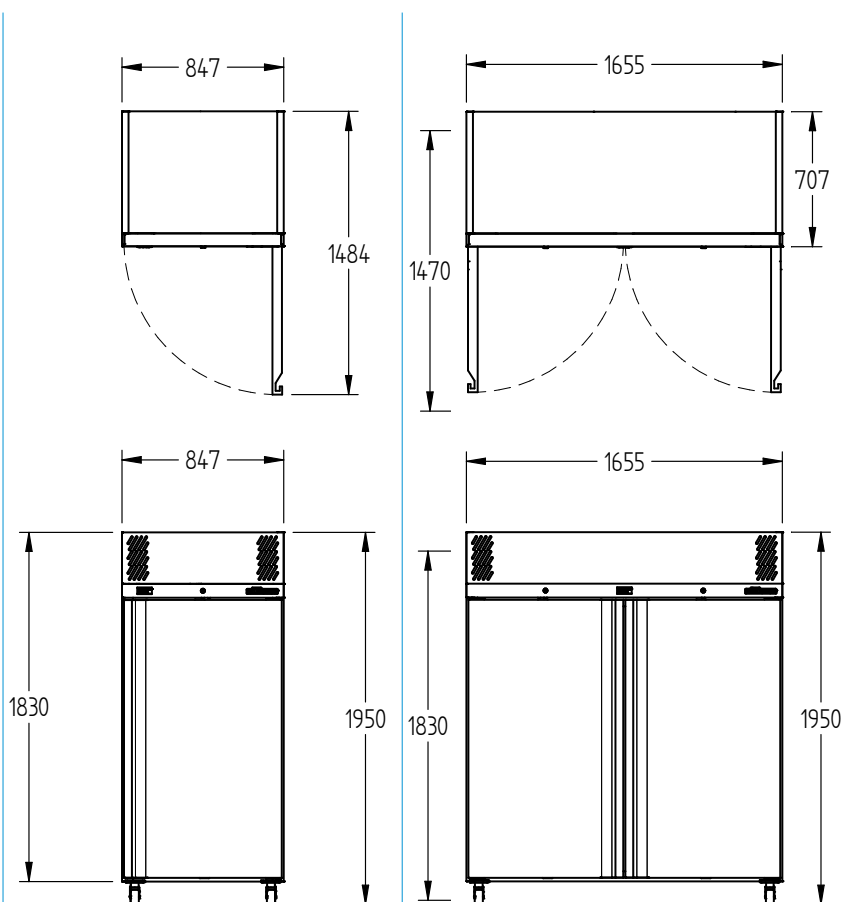
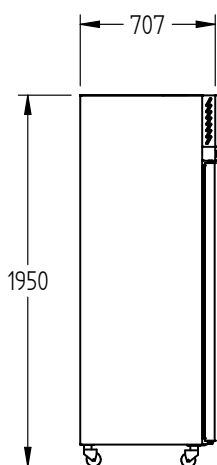

MODEL	1 DOOR		2 DOOR	
H (Refrigerator +1°/+4°C)	HS1SS	\$5,798	HS2SS	\$7,801
L (Freezer -18°/-22°C)	LS1SS	\$7,662	LS2SS	\$10,450

SPECIFICATIONS

CAPACITY LITRES	610	1270
DIMENSIONS - W X D X H (ON 120MM H CASTORS) MM	847 W x 707 D x 1950 H	1655 W x 707 D x 1950 H
WEIGHT UNPACKED (KG)	160	220

STANDARD INCLUSIONS ***

DOOR TYPE	Standard: S (Solid Door) Optional: HD (Half Door)	
FINISH (INTERIOR AND EXTERIOR EXCLUDING REAR AND UNDER)	S (Stainless Steel)	
SHELVES/DOOR	4	4

ELECTRICAL

POWER SUPPLY	10 amp	10 amp	
FRIDGE MODELS	RUNNING AMPS	2.8	3.8
FREEZER MODELS	RUNNING AMPS	4.5	5.2

GAS TYPE

REFRIGERANT	FRIDGE MODELS	R134a	R134a
	FREEZER MODELS	R404a	R404a

REFRIGERATION WATTAGES FOR OPTIONAL REMOTE UNITS

FRIDGE MODELS - SOLID DOORS	470 @ -5°C SST	670 @ -5°C SST
FREEZER MODELS - SOLID DOORS	630 @ -30°C SST	900 @ -30°C SST

*** For **Sapphire OPTIONS** see page 23

Prices do not include GST. Prices and specifications are subject to change without notice.

Options

Foodservice uprights

Garnet
Sapphire



Half doors



LED lighting to solid doors



Adjustable legs



Cylindrical locks



Shelves



Pass-through



Remote



Stainless steel shelves

OPTIONS	GARNET		SAPPHIRE	
	1 DOOR	2 DOOR	1 DOOR	2 DOOR
430 grade stainless steel rear & under	\$295	\$590	\$295	\$590
4622 stainless steel interior & exterior excluding rear and under	\$450	\$900	\$450	\$900
4622 stainless steel rear & under	\$355	\$710	\$355	\$710
430 grade stainless exterior 4622 stainless interior	\$295	\$590	\$295	\$590
Cylindrical locks	incl.	incl.	\$135	\$270
Light to solid doors	\$85	\$175	\$85	\$175
Extra plastic coated shelf (requires extra slides)	\$57	\$114	\$57	\$114
Extra pair of slides for shelf OR Gn pan	\$55	\$110	\$55	\$110
Stainless steel shelf upgrade (each)	\$195	\$390	\$195	\$390
Different temperature ranges: -2°/+2°C (meat solid door only) 0°/+3°C (chilled food) +5°/+10°C (wine)	\$245	\$329	\$245	\$329
Adjustable legs (150 mm high)	\$60	\$60	\$60	\$60
HALF DOORS IN LIEU OF FULL DOOR				
Solid doors	\$285	\$570	\$285	\$570
Cylindrical locks	\$270	\$540	\$270	\$540
PASS-THROUGH (refrigerator only)				
Solid doors	\$1,185	\$1,595	N/A	N/A
Cylindrical locks	\$270	\$540	N/A	N/A
REMOTE APPLICATION				
Refrigerator (deduct)	\$265	\$330	\$265	\$330
Freezer (deduct)	\$365	\$480	\$365	\$480

NOTES

- Optional adjustable legs (supplied loose) in lieu of castors adds 30 mm to overall height
- Pass-Through model may increase depth of cabinet by 50 mm
- Standard hinge on single door model: RHH (right hand hinged) when facing front of unit
- Optional door hang on single door (must be advised at time of order, new build only)
- Gas Type: Refrigerator—134a: Freezer—404a: Optional Remote (refrigerator and freezer) 404a

Foodservice counters



Opal

self contained



Electronic controller



Front breathing



Removable refrigeration cassette



Stainless steel worktop



10 Amp power

Opal cabinets are designed to perform in the harshest environments that kitchens can dish up. Through superior design and technology the Opal front breathing range doesn't miss a beat. Whether the cabinet has a blown air well or drawers it is the pinnacle of foodservice refrigerated cabinets.



Advantages

- 43°C ambient rating for hard working environments
- CoolSmart electronic controller for energy efficiency and even temperatures
- Easy clean coved internal liner
- Front breathing removable refrigeration cassette system for simple maintenance and easy servicing
- No need for external drain
- Face mounted hinges for plinth mounted
- Longer life anti corrosive evaporator coil coating
- Threaded castors allow simple leg changeover if required
- Intelligent ducted airflow distribution for greater even temperatures
- Peace of mind auto defrost
- Two adjustable shelves on adjustable strips and clips per door. (Blown air well models come with one shelf per door)
- Designed and built to international quality standards for reliability and performance—HACCP compliant
- Optional 1/1 Gastronorm racking system with anti-tilt slides for total flexibility
- Optional long life heavy duty drawer systems with two and three drawer modules in both refrigerator and freezer
- Optional blown air well system (on refrigerator only) with directional air flow above and below the pan gives consistent temperatures
- Blown air well models supplied with one shelf per door as standard
- Hot gas defrost on all freezer models

Foodservice counters

**BA MODEL
TOP VIEW**

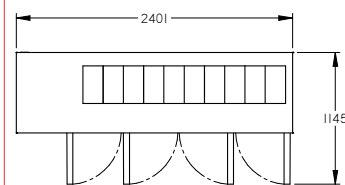
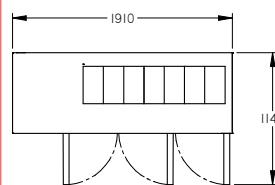
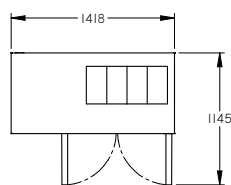
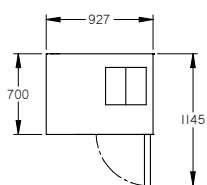

**STANDARD MODEL
TOP VIEW**

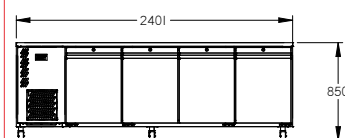
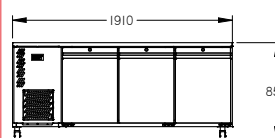
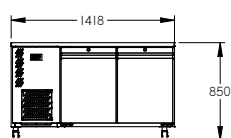
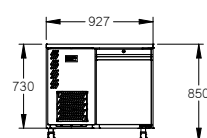
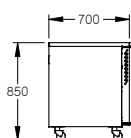
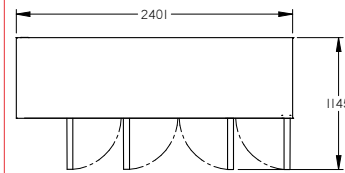
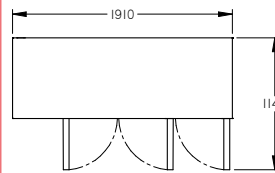
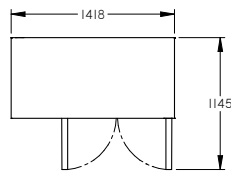
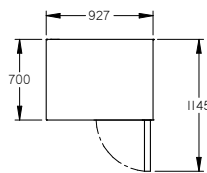

MODEL		1 DOOR	2 DOOR	3 DOOR	4 DOOR				
H (REFRIGERATOR +1°/+4°C)	(Front Breathing)	H01USS	\$4,149	H02USS	\$5,533	H03USS	\$7,156	H04USS	\$8,303
H (REFRIGERATOR +1°/+4°C)	BA (Blown Airwell) Pans 100 mm deep Gn (included)	H01USSBA 2 X 1/3	\$5,843	H02USSBA 4 X 1/3	\$7,669	H03USSBA 7 X 1/3	\$9,164	H04USSBA 10 X 1/3	\$11,042
L (FREEZER -18°/-22°C)	(Front Breathing)	L01USS	\$5,631	L02USS	\$7,808	L03USS	\$8,700		

SPECIFICATIONS

CAPACITY LITRES	190	350	510	670
DIMENSIONS - W X D X H (ON 120MM H CASTORS) MM	927 W x 700 D x 850 H	1418 W x 700 D x 850 H	1910 W x 700 D x 850 H	2401 W x 700 D x 850 H
WEIGHT UNPACKED (KG)	100	130	160	190

STANDARD INCLUSIONS ***

DOOR TYPE	Standard: S (Solid Door) Optional: D (Drawer), PT (Pass-Through)			
FINISH (INTERIOR AND EXTERIOR EXCLUDING REAR AND UNDER)	S (Stainless Steel)			
SHELVES/DOOR	2/1(BA)	2/1(BA)	2/1(BA)	2/1(BA)

ELECTRICAL

POWER SUPPLY	10 amp	10 amp	10 amp	10 amp	
FRIDGE MODELS	RUNNING AMPS	1.8	2.2	2.7	3.0
BLOWN AIRWELL MODELS	RUNNING AMPS	2.9	3.9	4.6	5.0
FREEZER MODELS	RUNNING AMPS	3.8	4.0	4.2	

GAS TYPE

REFRIGERANT	FRIDGE MODELS	R134a	R134a	R134a	R134a
	FREEZER MODELS	R404a	R404a	R404a	R404a

*** For **Opal OPTIONS** see page 33

Prices do not include GST. Prices and specifications are subject to change without notice.

Opal

remote



Electronic controller



Three-sided service connection



Easy access service compartment



Stainless steel worktop



10 Amp power

Opal Remote cabinets are designed to perform in the harshest environments that kitchens can dish up. Through superior design and technology and with a focus on a hassle free installation process the Opal remote range is a perfect fit. Whether the cabinet has a blown air well or drawers it is the pinnacle of foodservice refrigerated cabinets.



Advantages

- 43°C ambient rating for hard working environments
- CoolSmart electronic controller for energy efficiency and even temperatures
- Easy clean covered internal liner
- Simple hassle free installation with three access points on the cabinet body
- Generous service compartment allows flexibility for services location
- Face mounted hinges for plinth mounted
- Longer life anti corrosive evaporator coil coating
- Intelligent ducted airflow distribution for greater even temperatures
- Peace of mind auto defrost (electric on freezer models)
- Two adjustable shelves on adjustable strips and clips per door. (Blown air well models come with one shelf per door)
- Designed and built to international quality standards for reliability and performance—HACCP compliant
- Optional 1/1 Gastronorm racking system with anti-tilt slides for total flexibility
- Optional long life heavy duty drawer systems with two and three drawer modules in both refrigerator and freezer
- Optional blown air well system (on refrigerator only) with directional air flow above and below the pan gives consistent temperatures
- Blown air well models supplied with one shelf per door as standard

**BA MODEL
TOP VIEW**

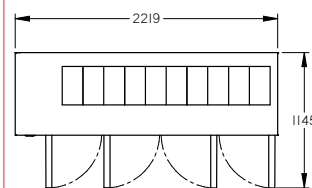
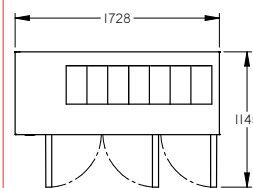
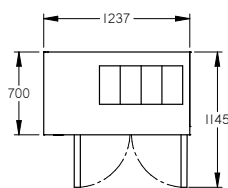
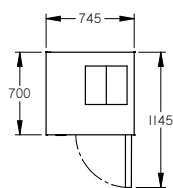

**STANDARD MODEL
TOP VIEW**

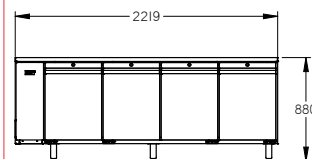
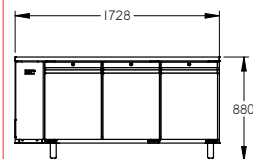
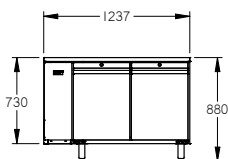
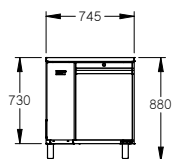
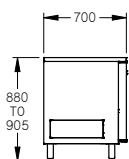
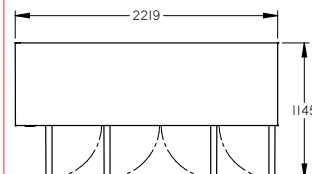
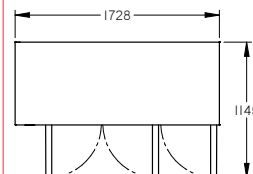
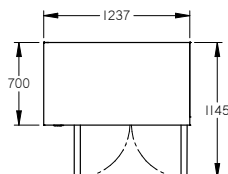
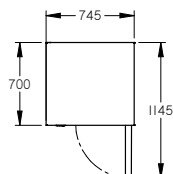

MODEL	1 DOOR		2 DOOR		3 DOOR		4 DOOR	
H (REFRIGERATOR +1°/+4°C)	H01RSS	\$3,844	H02RSS	\$5,243	H03RSS	\$6,355	H04RSS	\$7,192
H (REFRIGERATOR +1°/+4°C) BA (Blown Airwell) Pans 100 mm deep (included) Gn	H01RSSBA 2 X 1/3	\$5,602	H02RSSBA 4 X 1/3	\$7,254	H03RSSBA 7 X 1/3	\$9,254	H04RSSBA 10 X 1/3	\$10,000
L (FREEZER -18°/- 22°C)	L01RSS	\$5,253	L02RSS	\$6,820	L03RSS	\$8,197	L04RSS	\$9,679

SPECIFICATIONS

CAPACITY LITRES	190	350	510	670
DIMENSIONS - W X D X H (ON 150MM H LEGS)	745 W x 700 D x 880 H	1237 W x 700 D x 880 H	1728 W x 700 D x 880 H	2219 W x 700 D x 880 H
WEIGHT UNPACKED (KG)	90	120	150	180

STANDARD INCLUSIONS ***

DOOR TYPE	Standard: S (Solid Door) Optional: D (Drawer), PT (Pass-Through)			
FINISH (INTERIOR AND EXTERIOR EXCLUDING REAR AND UNDER)	S (Stainless Steel)			
SHELVES/DOOR	2/1(BA)	2/1(BA)	2/1(BA)	2/1(BA)

ELECTRICAL

POWER SUPPLY	10 amp	10 amp	10 amp	10 amp
FRIDGE MODELS RUNNING AMPS	0.4	0.5	0.6	0.7
FREEZER MODELS RUNNING AMPS	2.2	2.4	2.6	2.8

GAS TYPE

REFRIGERANT	FRIDGE MODELS	R404a	R404a	R404a	R404a
	FREEZER MODELS	R404a	R404a	R404a	R404a

REFRIGERATION WATTAGES FOR STANDARD REMOTE UNITS

FRIDGE MODELS - SOLID DOOR	280 @ -5°C SST	400 @ -5°C SST	500 @ -5°C SST	650 @ -5°C SST
FRIDGE MODELS - SOLID DOOR BA	430 @ -10°C SST	600 @ -10°C SST	750 @ -10°C SST	850 @ -10°C SST
FREEZER MODELS - SOLID DOOR	320 @ -30°C SST	450 @ -30°C SST	600 @ -30°C SST	680 @ -30°C SST

*** For **Opal Remote OPTIONS** see page 33

Prices do not include GST. Prices and specifications are subject to change without notice.

Emerald

self contained



Electronic controller



Front breathing



Removable refrigeration cassette



Stainless steel worktop



10 Amp power

Emerald cabinets are designed to perform in the harshest environments that kitchens can dish up. Through superior design and technology the Emerald front breathing range doesn't miss a beat. Whether the cabinet has a blown air well or drawers it is the pinnacle of foodservice refrigerated cabinets.



Advantages

- 43°C ambient rating for hard working environments
- CoolSmart electronic controller for energy efficiency and even temperatures
- Easy clean covered internal liner
- Front breathing removable refrigeration cassette system for simple maintenance and easy servicing
- No need for external drain
- Face mounted hinges for plinth mounted
- Longer life anti corrosive evaporator coil coating
- Threaded castors allow simple leg changeover if required
- Intelligent ducted airflow distribution for greater even temperatures
- Peace of mind auto defrost
- Two adjustable shelves on adjustable strips and clips per door. (Blown air well models come with one shelf per door)
- Designed and built to international quality standards for reliability and performance—HACCP compliant
- Optional 2/1 Gastronorm racking system with anti-tilt slides for total flexibility
- Optional long life heavy duty drawer systems with two and three drawer modules in both refrigerator and freezer
- Optional blown air well system (on refrigerator only) with directional air flow above and below the pan gives consistent temperatures
- Blown air well models supplied with one shelf per door as standard
- Hot gas defrost on all freezer models

**BA MODEL
TOP VIEW**

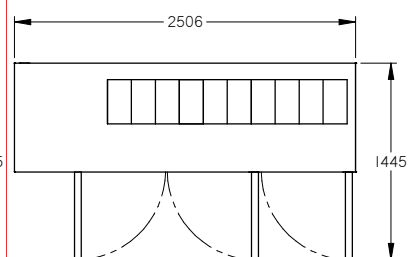
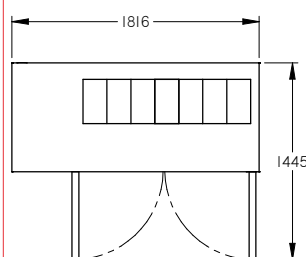
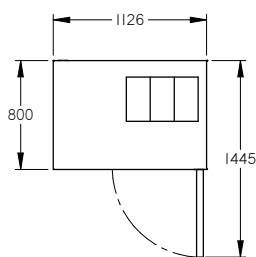

**STANDARD MODEL
TOP VIEW**

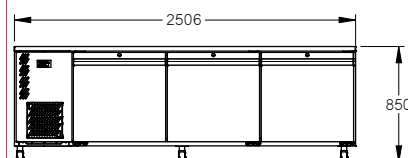
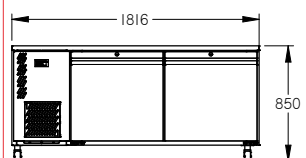
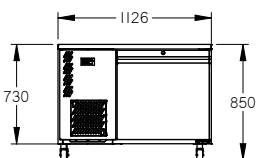
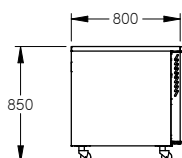
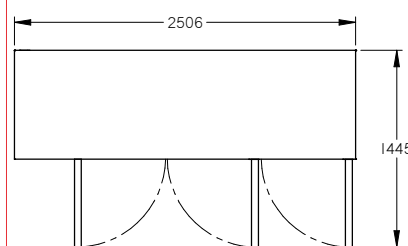
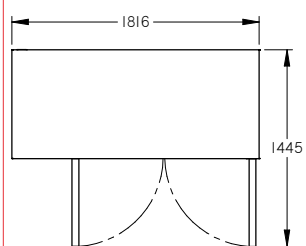
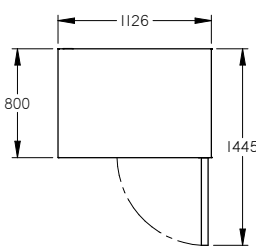

MODEL		1 DOOR		2 DOOR		3 DOOR	
H (REFRIGERATOR +1°/+4°C)	(Front Breathing)	HE1USS	\$4,667	HE2USS	\$6,253	HE3USS	\$7,942
H (REFRIGERATOR +1°/+4°C)	BA (Blown Airwell) Pans 100 mm deep (included) Gn	HE1USSBA 3 X 1/3	\$5,933	HE2USSBA 7 X 1/3	\$7,800	HE3USSBA 10 X 1/3	\$10,003
L (FREEZER -18°/-22°C)	(Front Breathing)	LE1USS	\$6,417	LE2USS	\$8,705		

SPECIFICATIONS

CAPACITY LITRES	310	610	900
DIMENSIONS - W X D X H (ON 120MM H CASTORS) MM	1126 W x 800 D x 850 H	1816 W x 800 D x 850 H	2506 W x 800 D x 850 H
WEIGHT UNPACKED (KG)	120	160	200

STANDARD INCLUSIONS ***

DOOR TYPE	Standard: S (Solid Door) Optional: D (Drawer), PT (Pass-Through)		
FINISH (INTERIOR AND EXTERIOR EXCLUDING REAR AND UNDER)	S (Stainless Steel)		
SHELVES/DOOR	2/1(BA)	2/1(BA)	2/1(BA)

ELECTRICAL

POWER SUPPLY	10 amp	10 amp	10 amp	
FRIDGE MODELS	RUNNING AMPS	1.8	2.2	2.7
BLOWN AIRWELL MODELS	RUNNING AMPS	3.6	4.6	5.2
FREEZER MODELS	RUNNING AMPS	4.2	4.8	

GAS TYPE

REFRIGERANT	FRIDGE MODELS	R134a	R134a	R134a
	FREEZER MODELS	R404a	R404a	R404a

*** For **Emerald OPTIONS** see page 33

Prices do not include GST. Prices and specifications are subject to change without notice.

Emerald

remote



Electronic controller



Three-sided service connection



Easy access service compartment



Stainless steel worktop



10 Amp power

Emerald Remote cabinets are designed to perform in the harshest environments that kitchens can dish up. Through superior design and technology and with a focus on a hassle free installation process the Emerald remote range is a perfect fit. Whether the cabinet has a blown air well or drawers it is the pinnacle of foodservice refrigerated cabinets.



Advantages

- 43°C ambient rating for hard working environments
- CoolSmart electronic controller for energy efficiency and even temperatures
- Easy clean covered internal liner
- Simple hassle free installation with three access points on the cabinet body
- Generous service compartment allows flexibility for services location
- Face mounted hinges for plinth mounted
- Longer life anti corrosive evaporator coil coating
- Intelligent ducted airflow distribution for greater even temperatures
- Peace of mind auto defrost (electric on freezer models)
- Two adjustable shelves on adjustable strips and clips per door. (Blown air well models come with one shelf per door)
- Designed and built to international quality standards for reliability and performance—HACCP compliant
- Optional 2/1 Gastronorm racking system with anti-tilt slides for total flexibility
- Optional long life heavy duty drawer systems with two and three drawer modules in both refrigerator and freezer
- Optional blown air well system (on refrigerator only) with directional air flow above and below the pan gives consistent temperatures
- Blown air well models supplied with one shelf per door as standard

**BA MODEL
TOP VIEW**

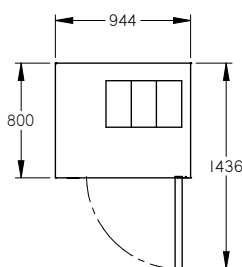

**STANDARD MODEL
TOP VIEW**

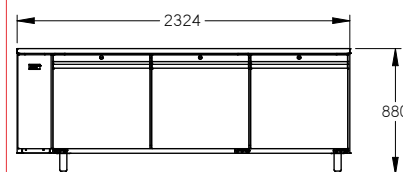
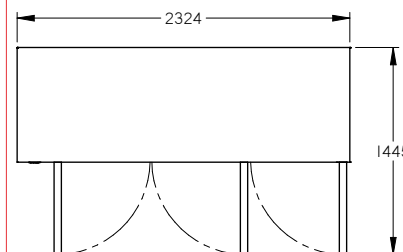
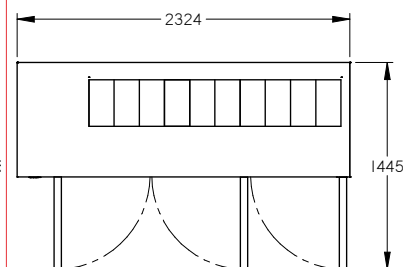
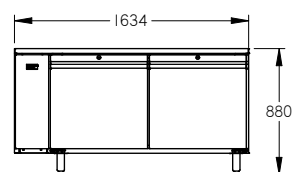
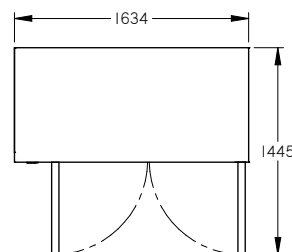
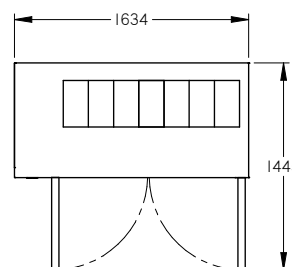
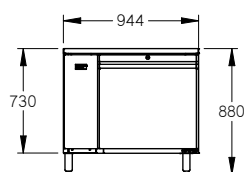
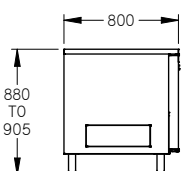
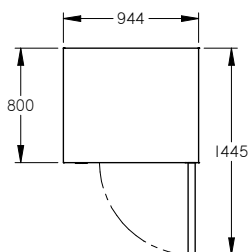

MODEL	1 DOOR		2 DOOR		3 DOOR	
H (REFRIGERATOR +1°/+4°C)	HE1RSS	\$4,475	HE2RSS	\$5,839	HE3RSS	\$7,632
H (REFRIGERATOR +1°/+4°C)	HE1RSSBA 3 X 1/3	\$5,214	HE2RSSBA 7 X 1/3	\$7,666	HE3RSSBA 10 X 1/3	\$9,424
L (FREEZER -18°/-22°C)	LE1RSS	\$6,166	LE2RSS	\$7,504	LE3RSS	\$11,060

SPECIFICATIONS

CAPACITY LITRES	310	610	900
DIMENSIONS - W X D X H (ON 150MM H LEGS)	944 W x 800 D x 880 H	1634 W x 800 D x 880 H	2324 W x 800 D x 880 H
WEIGHT UNPACKED (KG)	110	150	200

STANDARD INCLUSIONS ***

DOOR TYPE	Standard: S (Solid Door) Optional: D (Drawer), PT (Pass-Through)		
FINISH (INTERIOR AND EXTERIOR EXCLUDING REAR AND UNDER)	S (Stainless Steel)		
SHELVES/DOOR	2/1(BA)	2/1(BA)	2/1(BA)

ELECTRICAL

POWER SUPPLY	10 amp	10 amp	10 amp
FRIDGE MODELS	RUNNING AMPS	0.4	0.5
FREEZER MODELS	RUNNING AMPS	2.3	2.7
			3.1

GAS TYPE

REFRIGERANT	FRIDGE MODELS	R404a	R404a	R404a
	FREEZER MODELS	R404a	R404a	R404a

REFRIGERATION WATTAGES FOR STANDARD REMOTE UNITS

FRIDGE MODELS - SOLID DOOR	350 @ -5°C SST	500 @ -5°C SST	650 @ -5°C SST
FRIDGE MODELS - SOLID DOOR BA	600 @ -10°C SST	750 @ -10°C SST	980 @ -10°C SST
FREEZER MODELS - SOLID DOOR	430 @ -30°C SST	610 @ -30°C SST	780 @ -30°C SST

*** For **Emerald Remote OPTIONS** see page 33

Prices do not include GST. Prices and specifications are subject to change without notice.

Options

Foodservice counters

Opal
Opal remote
Emerald
Emerald remote



Right-hand services



Drawers



Black finish



Adjustable legs



Cylindrical locks



Pass-through



Locking tabs



Stainless steel shelves

OPTIONS	OPAL				EMERALD		
	1 DOOR	2 DOOR	3 DOOR	4 DOOR	1 DOOR	2 DOOR	3 DOOR
430 grade stainless steel rear & under	\$185	\$370	\$555	\$740	\$185	\$370	\$555
4622 stainless steel interior & exterior excluding rear and under	\$385	\$770	\$1,155	\$1,540	\$385	\$770	\$1,155
4622 stainless steel rear & under	\$285	\$570	\$855	\$1,140	\$285	\$570	\$855
430 grade stainless exterior 4622 stainless interior	\$255	\$510	\$765	\$1,020	\$255	\$510	\$765
Black finish interior & exterior (deduct)	\$150	\$170	\$190	\$210	\$150	\$170	\$190
Cylindrical locks	\$135	\$270	\$405	\$540	\$135	\$270	\$405
Locking tabs	\$30	\$60	\$90	\$120	\$30	\$60	\$90
Light to solid doors	\$155	\$155	\$310	\$465	\$155	\$155	\$310
Extra plastic coated shelf (ladder racking requires extra slides)	\$57	\$114	\$171	\$228	\$57	\$114	\$171
GN ladder racking 2 pair of slides for shelf/pan per door	\$110	\$220	\$330	\$440	\$110	\$220	\$330
Extra pair of slides for shelf/pan	\$55	\$110	\$165	\$220	\$55	\$110	\$165
Stainless steel shelf upgrade (each)	\$195	\$390	\$585	\$780	\$195	\$390	\$585
Special well sizes (BA only)	\$550	\$1,140	\$1,630	\$2,210	\$550	\$1,140	\$1,630
Splashback to worktop (135 mm high from worktop)	\$300	\$500	\$700	\$900	\$300	\$500	\$700
Adjustable legs (150 mm high, included on remotes)	\$60	\$60	\$60	\$90	\$60	\$60	\$90
RH services (services to right hand side)	\$215						
Solenoid fitted (remote only)	\$295						
Hand valves fitted (remote only)	\$250						
Remote application in self contained body (deduct)	Deduct \$185						
Larger castors (increases to 900 mm work bench height)	\$110						
PASS-THROUGH: (fridge only) **							
Solid doors	\$845	\$1,690	\$2,535	\$3,380	\$845	\$1,690	\$2,535
DRAWERS (per door equivalent)(check configuration prior to order)							
2 bank FULL drawer set per door (150 mm deep—pans excluded)	\$1,195 Fridge / \$1,425 Freezer						
3 bank FULL drawer set per door (100 mm deep—pans excluded)	\$1,448 Fridge / \$1,808 Freezer (N/A FOR BA)						
IMPORTANT NOTES							

- No models available as glass door option
- Total height of 850 mm on self contained models includes castors
- Optional adjustable legs (supplied loose) in lieu of castors adds 30 mm to total height
- Optional door hang on single door (must be advised at time of order)
- BA models with drawers—two drawer version only, 100 mm deep pans
- ** Pass-through models increases depth of cabinet by 50 mm
- BA models are supplied with polycarbonate lids
- Gas Type: Refrigerator—134a: Freezer—404a: Remote (refrigerator and freezer) 404a

A modern outdoor lounge area featuring a large, lush living wall of various green plants. In the foreground, there is a brown leather sofa with patterned cushions, a black coffee table with books and plants, and a large grey beanbag chair. To the left, there are several tables and chairs, some with white frames and others with dark frames. The background shows a building with large windows and a wooden facade. The overall atmosphere is warm and inviting, with soft lighting.

Hydrocarbon

Jade Hydrocarbon

self contained



Digital controller



Hydrocarbon



Full length handle



Cylindrical locks



10 amp power

The Hydrocarbon (R290) Jade range is designed for the toughest kitchen environments and offers outstanding performance, efficiency and reliability. These storage cabinets come in a one or two door configuration with your choice of both fridge and freezer. The advanced temperature control ensures easy-to-manage operation in even the most demanding high-ambient environments.



Advantages

- R290 natural refrigerant
- Reduced running costs
- Gastronorm (Gn 2/1) cabinet (top mounted versions only) (bottom mounted J400 are non Gn units)
- Easy to clean, full length integral handle
- Energy saving CoolSmart controller ensures excellent temperature control and easy-to-manage operation.
- Designed for effective operation in high ambient 43°C environments, and built to withstand the rigours of day-to-day operation
- Self-closing door fitted with easy to clean, replaceable magnetic balloon gasket for 100% seal
- Construction includes 80mm polyurethane insulation with zero ODP and low GWP and provides excellent thermal efficiency.
- Delivered to site with heavy duty, non-marking swivel castors with brakes for superior mobility and stability. The height of the Jade with castors is designed to fit through a standard door for ease of positioning.
- Enhanced airflow design for uniform cooling, with no potential warm spots

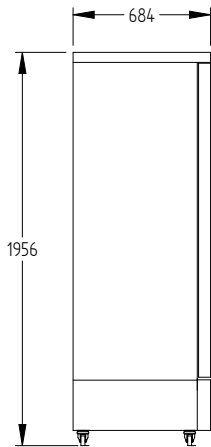

**J400 MODEL
SIDE VIEW**

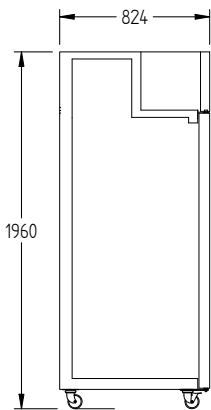

**J1SA MODEL
J2SA MODEL
SIDE VIEW**

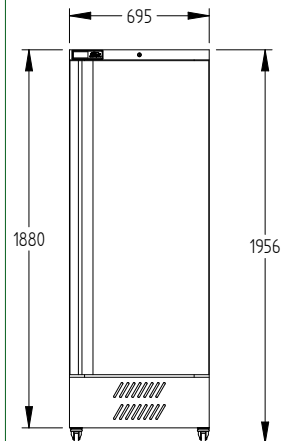
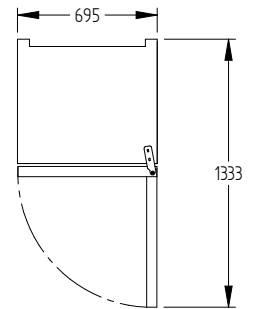
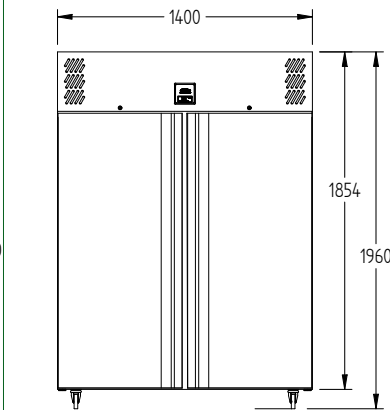
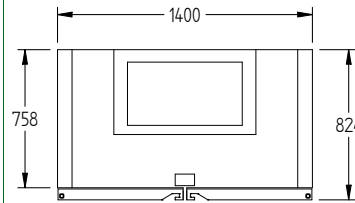
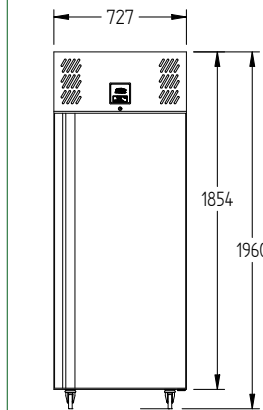
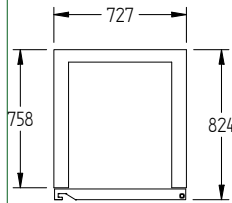

MODEL	1 DOOR		2 DOOR		1 DOOR	
H (REFRIGERATOR +1°/+4°C)	HJ1SA-HC	\$5,788	HJ2SA-HC	\$8,535	HJ400-HC	\$5,544
L (FREEZER -18°/-22°C)	LJ1SA-HC	\$7,040	LJ2SA-HC	\$10,800	LJ400-HC	\$6,963

SPECIFICATIONS

CAPACITY LITRES	620	1295	410
DIMENSIONS - W X D X H (ON CASTORS) MM	727 W x 824 D x 1960 H	1400 W x 824 D x 1960 H	695 W x 684 D x 1956 H
WEIGHT UNPACKED (KG)	200	250	180

STANDARD INCLUSIONS ***

DOOR TYPE

Standard: S (Solid Door)

FINISH (INTERIOR AND EXTERIOR EXCLUDING REAR AND UNDER)

SA (Stainless Steel Exterior, Aluminium Interior)

SHELVES/DOOR

3

3

3(H) / 6(L) fixed

ELECTRICAL

POWER SUPPLY	10 amp	10 amp	10 amp	
FRIDGE MODELS	RUNNING AMPS	1.64	1.42	1.75
FREEZER MODELS	RUNNING AMPS	2.8	3.63	1.91

GAS TYPE

REFRIGERANT	FRIDGE MODELS	R290	R290	R290
	FREEZER MODELS	R290	R290	R290

Prices do not include GST. Prices and specifications are subject to change without notice.

Opal Hydrocarbon

self contained



Digital controller



Front breathing



Hydrocarbon



Removable cassette



10 amp power

The Hydrocarbon (R290) Opal front breathing range is designed for the toughest kitchen environments and offers outstanding performance, efficiency and reliability. These 1/1 Gastronorm (Gn) storage cabinets come in a two, three, or four door configuration. The advanced temperature control ensures easy-to-manage operation in even the most demanding high-ambient environments.



Advantages

- 43°C ambient rating for hard working environments
- R290 natural refrigerant
- Front breathing removable refrigeration cassette system for simple maintenance and easy servicing
- Reduced running costs
- CoolSmart electronic controller for energy efficiency and even temperatures
- Easy clean covered internal liner
- Easy to clean, full length horizontal integral handle
- No need for external drain
- Face mounted hinges for plinth mounted
- Longer life anti corrosive evaporator coil coating
- Threaded castors allow simple leg changeover if required
- Intelligent ducted airflow distribution for greater even temperatures
- Two adjustable shelves on adjustable strips and clips per door
- Peace of mind auto defrost
- Designed and built to international quality standards for reliability and performance—HACCP compliant
- Optional 1/1 Gn racking system for total flexibility
- Enhanced airflow design for uniform cooling, with no potential warm spots
- Hot gas defrost on all freezer models

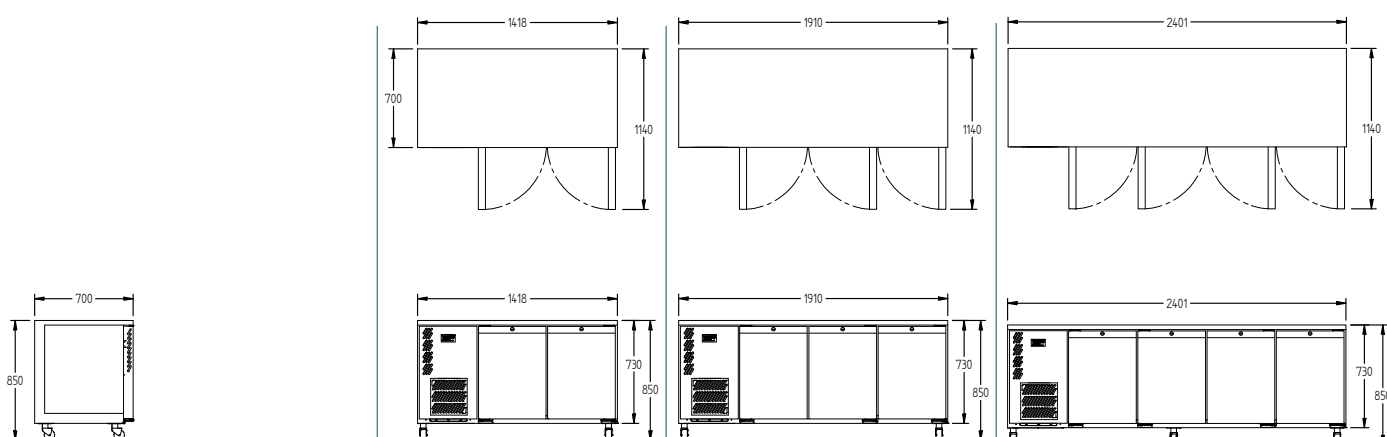

MODEL	2 DOOR		3 DOOR		4 DOOR	
H (REFRIGERATOR +1°/+4°C)	HO2USS-HC	\$5,671	HO3USS-HC	\$7,334	HO4USS-HC	\$8,510
L (FREEZER -18°/-22°C)	LO2USS-HC	\$8,004	LO3USS-HC	\$8,918	—	—

SPECIFICATIONS

CAPACITY LITRES	350	510	670
DIMENSIONS - W X D X H (ON 120MM H CASTORS) MM	1418 W x 700 D x 850 H	1910 W x 700 D x 850 H	2401 W x 700 D x 850 H
WEIGHT UNPACKED (KG)	130	160	190

STANDARD INCLUSIONS ***

DOOR TYPE	Standard: S (Solid Door)		
FINISH (INTERIOR AND EXTERIOR EXCLUDING REAR AND UNDER)	S (Stainless Steel)		
SHELVES/DOOR	2	2	2

ELECTRICAL

POWER SUPPLY	10 amp	10 amp	10 amp
FRIDGE MODELS	RUNNING AMPS	1.68	1.68
FREEZER MODELS	RUNNING AMPS	2.58	N/A

GAS TYPE

REFRIGERANT	FRIDGE MODELS	R290	R290	R290
	FREEZER MODELS	R290	R290	N/A

Prices do not include GST. Prices and specifications are subject to change without notice.

Meat Aging Refrigerator

self contained



Digital controller



Hydrocarbon



Activated charcoal filter



Pink Himalayan salt blocks



10 amp power

Stylish design is combined with a robust, all stainless-steel construction along with running on environmentally friendly R290 gas. The meat ageing refrigerator can operate in environments of up to 43°C and its interior is brightly lit with energy saving LEDs, making it ideal for front of house display. The perfect meat ageing conditions are maintained by providing humidity between 60-90% and the inclusion of Himalayan salt blocks that assist with moisture management and improves the flavour of the meat.

Capacity and versatility are well managed – the cabinet has four 2/1 Gn perforated stainless steel shelves with anti-tilt tray slides, each able to hold a maximum of 20kg per shelf.



Advantages

- R290 natural refrigerant.
- Designed for effective operation in high ambient 43°C environments, and built to withstand the rigours of day-to-day operation
- Operating temperature of +1 to +6°C and humidity between 60-90%
- Himalayan salt blocks to assist with moisture management and improvement of flavour
- Foodsafe professional stainless-steel interior and exterior
- Four 2/1 Gn perforated stainless steel shelves with anti-tilt tray slides
- Robust, easy to grab, full length, stainless steel door handle
- Self-closing door fitted with easy to clean, replaceable magnetic balloon gaskets for 100% seal
- Energy saving CoolSmart controller ensures excellent temperature control and easy-to-manage operation.
- Enhanced airflow design for uniform cooling
- Internal bright, low heat, LED strip lighting offer great energy savings and clear visibility of meat
- Construction includes 80mm polyurethane insulation with zero ODP and low GWP and provides excellent thermal efficiency.
- Delivered to site with heavy duty, non-marking swivel castors with brakes for superior mobility and stability. Fits through a standard door for ease of positioning.

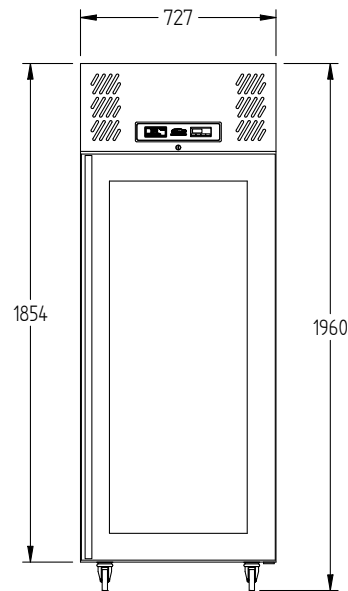
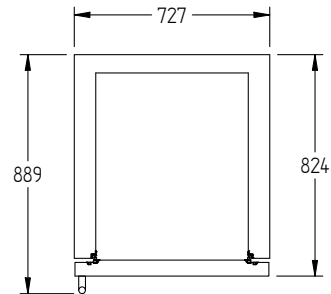
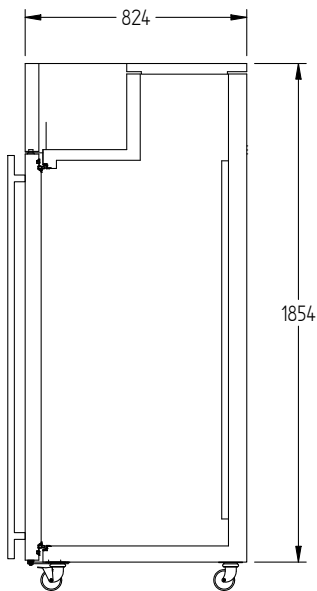

MODEL	1 DOOR	
H (REFRIGERATOR +1°/+6°C)	MAR1-HC	\$11,012
SPECIFICATIONS		
CAPACITY LITRES	620	
DIMENSIONS - W X D X H (ON CASTORS) MM	727 W x 889 D x 1960 H	
WEIGHT UNPACKED (KG)	230	
STANDARD INCLUSIONS		
DOOR TYPE	Standard: GD (Glass Door)	
FINISH (INTERIOR AND EXTERIOR EXCLUDING REAR AND UNDER)	SS (Stainless Steel)	
SHELVES/DOOR	4	
ELECTRICAL		
POWER SUPPLY	10 amp	
RUNNING AMPS	1.65	
GAS TYPE		
REFRIGERANT	R290	

Prices do not include GST. Prices and specifications are subject to change without notice.

Aztra Hydrocarbon

self contained



Digital controller



Hydrocarbon



GN pan compatible



Easy grab door handle



10 amp power

The Hydrocarbon Aztra range is a compact front-vented undercounter, the AZ5UC is ideal for environments where space is at a premium. Despite its small footprint it has a little over 113 Litres of storage and is capable of holding 1/1 Gastronorm trays.



Advantages

- Natural hydrocarbon refrigerant
- Reduced running costs
- Gastronorm (Gn 1/1) cabinet
- Integral handle for an easy 'grab' on the door
- Fitted with 2 of 1/1Gn nylon coated wire shelves per section as standard or tray slides to accommodate 1/1Gn containers
- Anti-tilt tray slides
- Removable racking system
- Self-closing door
- Energy saving CoolSmart controller ensures excellent temperature control and easy-to-manage operation
- Designed for effective operation in high ambient 43°C environments, and built to withstand the rigours of day-to-day operation
- Self-closing door fitted with easy to clean, replaceable magnetic balloon gasket for 100% seal Low GWP, Zero ODP polyurethane insulation. Defrost water is vaporised using recycled heat from compressor
- Castors to rear, adjustable feet to front for mobility and stability
- Enhanced airflow design for uniform cooling, with no potential warm spots

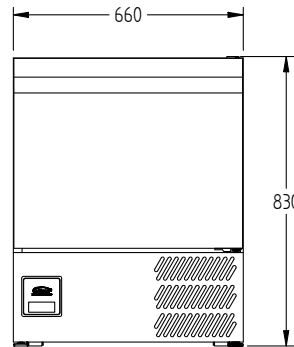
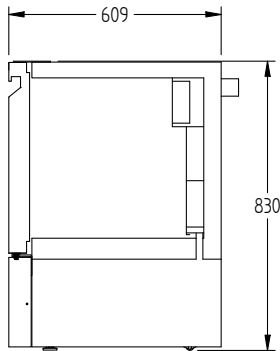
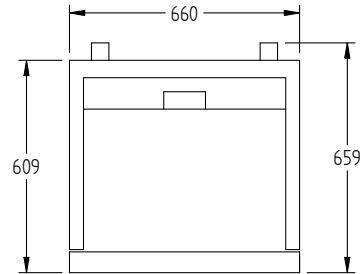

MODEL	1 DOOR	
H (REFRIGERATOR +1°/+4°C)	HAZ5UC-HC	\$4,239
L (FREEZER -18°/-22°C)	LAZ5UC-HC	\$4,517
SPECIFICATIONS		
CAPACITY LITRES	131	
DIMENSIONS - W X D X H (ON CASTORS) MM	660 W x 609 D x 830 H	
WEIGHT UNPACKED (KG)	150	
STANDARD INCLUSIONS		
DOOR TYPE	Standard: S (Solid Door)	
FINISH (INTERIOR AND EXTERIOR EXCLUDING REAR AND UNDER)	SA (Stainless Steel Exterior, Aluminium Interior)	
SHELVES/DOOR	2	
ELECTRICAL		
POWER SUPPLY	10 amp	
FRIDGE MODELS	RUNNING AMPS	0.53
FREEZER MODELS	RUNNING AMPS	2.46
GAS TYPE		
REFRIGERANT	FRIDGE MODELS	R600A
	FREEZER MODELS	R290

Prices do not include GST. Prices and specifications are subject to change without notice.

Vari Temp Drawer

self contained



Digital controller



Hydrocarbon



GN pan compatible



Variable temperature



10 amp power

The Vari Temp Drawer is the ultimate in convenience, providing bulk storage of fresh or frozen food right where you need it the most. The low level single height unit or its double stacked option is perfect for suiting any situation. It is a large, space saving refrigerator/freezer drawer units and is an ideal solution for pubs, steakhouses, and catering facilities where space is often limited. It also runs on environmentally friendly R290 refrigerant.



Advantages

- R290 natural refrigerant
- Can be adjusted between Fridge and Freezer temperatures according to what is required
- Large capacity drawer size 2 x 1 Gn (150mm maximum depth)
- Stacking capability for convenient refrigerator / freezer combination
- Easy to access built in refrigeration system
- Foodsafe stainless steel exterior and interior
- Heavy duty, non-marking swivel castors with brakes
- Magnetic balloon door gaskets with 100% tight seal
- CoolSmart controller
- Precision injected, high density polyurethane insulation with low GWP (Global Warming Potential) and zero ODP (Ozone Depletion Potential)
- Designed and engineered to operate efficiently up to a 43°C ambient
- High performance helium leak testing

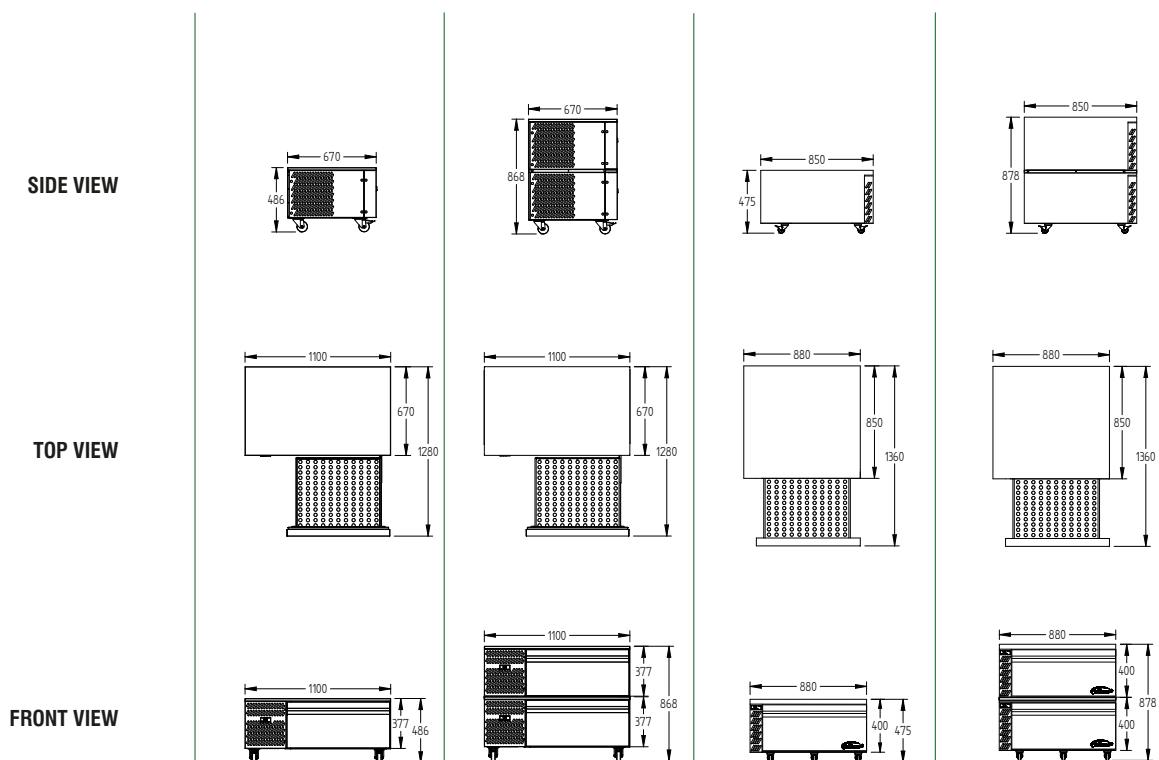

MODEL	VSWCD1-HC		VSWCD1S-HC		VRWCD1-HC		VRWCD1S-HC	
VARIABLE +1°/-22°C SELF CONTAINED	VSWCD1-HC	\$5,450	VSWCD1S-HC	\$10,306	VRWCD1-HC	\$6,722	VRWCD1S-HC	\$13,444
SPECIFICATIONS								
CAPACITY 1/1 GN PAN	2 (150 mm deep)		4 (150 mm deep)		2 (150 mm deep)		4 (150 mm deep)	
DIMENSIONS - W X D X H (ON CASTORS) MM	1100 W x 670 D x 486 H		1100 W x 670 D x 868 H		880 W x 850 D x 475 H		880 W x 850 D x 878 H	
WEIGHT UNPACKED (KG)	200		400		200		400	
STANDARD INCLUSIONS								
DRAWERS	1		2		1		2	
FINISH (INTERIOR AND EXTERIOR EXCLUDING REAR AND UNDER)	SS (Stainless Steel)		SS (Stainless Steel)		SS (Stainless Steel)		SS (Stainless Steel)	
ELECTRICAL								
POWER SUPPLY	10 amp		10 amp x 2		10 amp		10 amp x 2	
RUNNING AMPS	1.89		1.89 x 2		1.48		1.48 x 2	
GAS TYPE								
REFRIGERANT	R290		R290		R290		R290	

Prices do not include GST. Prices and specifications are subject to change without notice.

Amber Hydrocarbon

self contained



Digital controller



Hydrocarbon



Cylindrical locks



Low noise design



10 amp power

The Hydrocarbon Amber range is a compact and ideal for small kitchens, the 135 Litre Amber A-135 is a robust undercounter cabinet that maximises the space available.



Advantages

- Natural hydrocarbon refrigerants
- Reduced running costs
- High performance, front vented refrigeration system
- CoolSmart controller
- Integral handle for an easy 'grab' on the door
- Designed to operate efficiently up to 32°C ambient
- Fitted with nylon coated, adjustable wire shelves on refrigerator models and static shelves on freezers.
- Self-closing door fitted with easy to clean, replaceable magnetic balloon gasket for 100% seal
- Cylindrical door lock
- Low GWP, Zero ODP polyurethane insulation
- Defrost water is vaporised using recycled heat from compressor (fridge only)
- Castors to rear, adjustable feet to front for mobility and stability
- Enhanced airflow design for uniform cooling, with no potential warm spots

FREEZER SIDE VIEW

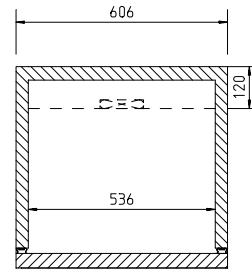
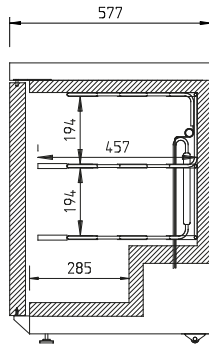

FRIDGE SIDE VIEW

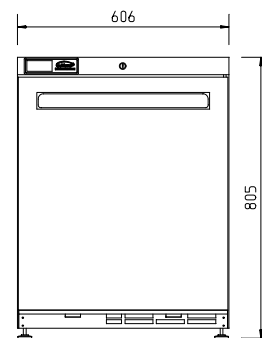
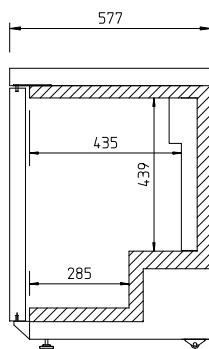

MODEL	1 DOOR	
H (REFRIGERATOR +1°/+4°C)	HA135-HC	\$4,136
L (FREEZER -18°/-22°C)	LA135-HC	\$4,406
SPECIFICATIONS		
CAPACITY LITRES	135	
DIMENSIONS - W X D X H (ON CASTORS) MM	606 W x 577 D x 805 H	
WEIGHT UNPACKED (KG)	65	
STANDARD INCLUSIONS		
DOOR TYPE	Standard: S (Solid Door)	
FINISH (INTERIOR AND EXTERIOR EXCLUDING REAR AND UNDER)	SA (Stainless Steel Exterior, Aluminium Interior)	
SHELVES/DOOR	2	
ELECTRICAL		
POWER SUPPLY	10 amp	
FRIDGE MODELS	RUNNING AMPS	0.53
FREEZER MODELS	RUNNING AMPS	1.3
GAS TYPE		
REFRIGERANT	FRIDGE MODELS	R600A
	FREEZER MODELS	R290

Prices do not include GST. Prices and specifications are subject to change without notice.

Salads

BAKER'S
in the
16

BURGERS

CHICKEN
PARMIGIANA
22

HOUSE
Specials

20



THE BEST PIZZA

BAKER'S
in the
16

BURGERS

WELL DONE BEEF BURGER ON SPECIAL BUN \$12.95
 ALL THE CLASSIC BUNNY CARBSBURGER \$12.95
 THE PORK ONE \$12.95
 LAMB BURGER \$12.95
 STEAK SANDWICH \$12.95
 FRESHLY COOKED CHICKEN BURGER \$12.95
 GUY'S TOP \$12.95
 WARRIORS \$12.95
 PORK BURGER \$12.95

CHICKEN
PARMIGIANA

GOLDEN CRUMBED CHICKEN
 LAMBED BY GARL GARL
 EGGPLANT RICH MARIGLIANA
 SAUCE, BREADCRUMBS
 MOZZARELLA CHEESE
 + CREAMY GARLIC SAUCE

22

HOUSE
Specials

TWICE COOKED PULLED PORK \$16
 ROLL FRESH BREAD, MUSTARD, Aged
 + SHREDDED CHEESE

SHEEP BUCKET ROLL \$16
 THE BEST OF BRISTOL STICKY SWEET
 PEACHY SAUCE, Aged, SHREDDED

12 HR BRANDED LAMB ROLL \$16
 GARLIC CHIVE + BREADCRUMBS
 Aged + SHREDDED CHEESE

SPICY CHICKEN ROLL \$16
 GARLIC CHIVE + BREADCRUMBS
 Aged + SHREDDED CHEESE

THE BOSS \$17
 TWICE COOKED PULLED
 PORK, SUN DRIED TOMATOES, Aged
 + SHREDDED CHEESE

THE REAL REVEN \$16
 GARLIC CHIVE + BREADCRUMBS
 Aged + SHREDDED CHEESE

FISH CHIPS BASKET \$18
 COOKED FRESH BREAD, FISH
 SHREDDED PORK + HOUSE SAUCE

20

FORK & CHIVE BANG
 MUSTARD INFUSED M
 RUSTIC MINTED PE
 CARAMELISED ONIO
 SIGNATURE GRAVY

Bakery



Opal Bakery

self contained



Digital controller



Front breathing



600mm x 400mm racking



600mm x 400mm bakery tray compatible



10 amp power

An Australian made purpose built undercounter unit for the bakery industry with a choice of a two or three door models both available in either a fridge or a freezer. All undercounter units are manufactured to accommodate 600 mm x 400 mm bakery trays.



Advantages

- 43°C ambient rating for hard working environments
- CoolSmart electronic controller for energy efficiency and even temperatures
- Easy clean coved internal liner
- Front breathing removable refrigeration cassette system for simple maintenance and easy servicing
- No need for external drain
- Face mounted hinges for plinth mounting
- Longer life anti corrosive evaporator coil coating
- Threaded castors allow simple leg changeover if required
- Intelligent ducted airflow distribution for greater even temperatures
- Manufactured to accommodate 5 x 600 mm x 400 mm bakers trays per door
- 75 mm spacing between slides
- Designed and built to international quality standards for reliability and performance

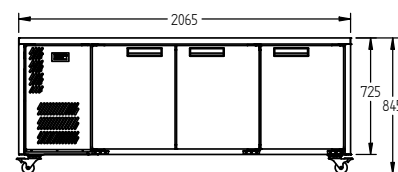
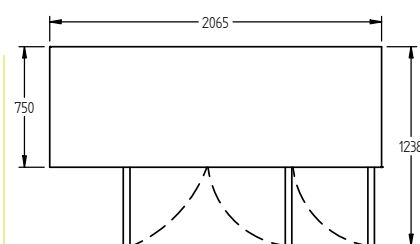
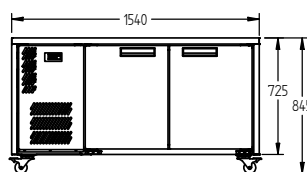
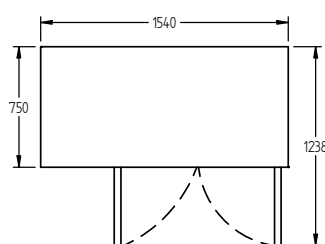
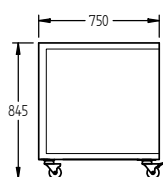

MODEL		2 DOOR		3 DOOR	
R (RETARDER -5°/+3°C)	FB (FRONT BREATHING)	ROB2UFB	\$6,522	ROB3UFB	\$8,435
L (FREEZER -13°/-21°C)	FB (FRONT BREATHING)	LOB2UFB	\$9,205	LOB3UFB	\$10,256

SPECIFICATIONS

CAPACITY LITRES	380	585
DIMENSIONS - W X D X H (ON 120MM H CASTORS) MM	1540 W x 750 D x 845 H	2065 W x 750 D x 845 H
WEIGHT UNPACKED (KG)	150	190

STANDARD INCLUSIONS ***

DOOR TYPE	Standard S (Solid Door)	
FINISH (INTERIOR AND EXTERIOR EXCLUDING REAR AND UNDER)	S (Stainless Steel)	
TRAY SLIDE PAIRS/DOOR (NO TRAYS OR SHELVES SUPPLIED)	5	5

ELECTRICAL

POWER SUPPLY	10 amp	10 amp	
FRIDGE MODELS	RUNNING AMPS	2.8	3.1
FREEZER MODELS	RUNNING AMPS	4.5	4.7

GAS TYPE

REFRIGERANT	FRIDGE MODELS	R134a	R134a
	FREEZER MODELS	R404a	R404a

*** For **Opal Bakery OPTIONS** see page 55

Prices do not include GST. Prices and specifications are subject to change without notice.

Garnet Bakery

self contained



Electronic controller



Top mounted



600mm x 400mm
bakery tray compatible



Internal racking with
tray slides



10 Amp power

An Australian made cabinet purpose built for the bakery industry with a choice of a one or two door model with various options. Manufactured specifically to fit 400 mm x 600 mm bakery trays in either a single door or double door, fridge or freezer option.



Advantages

- 43°C ambient rating for hard working environments
- CoolSmart electronic controller for energy efficiency and even temperatures
- Easy clean covered internal liner
- Top mounted removable refrigeration system for simple maintenance and easy servicing
- Waste heat recovery vaporiser system—no need for external drain
- Threaded castors allow simple leg changeover if required
- Manufactured to accommodate 10 x 600 mm x 400 mm trays per door
- 75 mm spacing between slides
- Designed and built to international quality standards for reliability and performance
- Peace of mind auto defrost (electric on freezer models)

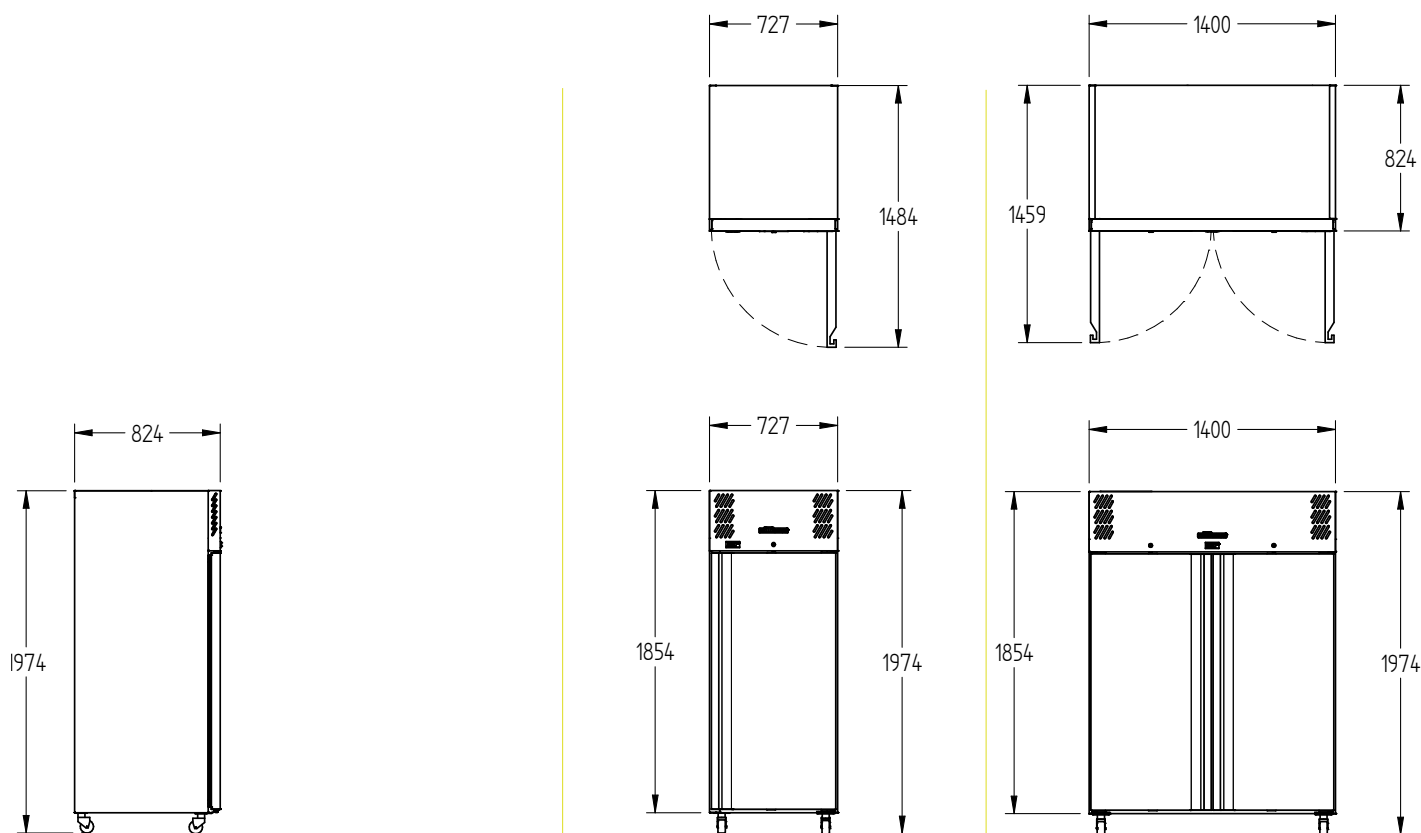

MODEL	1 DOOR		2 DOOR	
R (RETARDER -5°/+3°C)	RGB1SS	\$5,689	RGB2SS	\$7,653
L (FREEZER -13°/-21°C)	LGB1SS	\$7,217	LGB2SS	\$9,843

SPECIFICATIONS

CAPACITY LITRES	610	1270
DIMENSIONS - W X D X H (ON 120MM H CASTORS) MM	727 W x 824 D x 1974 H	1400 W x 824 D x 1974 H
WEIGHT UNPACKED (KG)	170	220

STANDARD INCLUSIONS ***

DOOR TYPE	Standard: S (Solid Door)	
FINISH (INTERIOR AND EXTERIOR EXCLUDING REAR AND UNDER)	S (Stainless Steel)	
TRAY SLIDE PAIRS/DOOR (NO TRAYS OR SHELVES SUPPLIED)	10	10

ELECTRICAL

POWER SUPPLY	10 amp	10 amp	
FRIDGE MODELS	RUNNING AMPS	2.8	3.8
FREEZER MODELS	RUNNING AMPS	4.5	5.2

GAS TYPE

REFRIGERANT	FRIDGE MODELS	R134a	R134a
	FREEZER MODELS	R404a	R404a

REFRIGERATION WATTAGES FOR OPTIONAL REMOTE UNITS

FRIDGE MODELS - SOLID DOORS	470 @ -5°C SST	670 @ -5°C SST
FREEZER MODELS - SOLID DOORS	630 @ -30°C SST	900 @ -30°C SST

*** For **Garnet Bakery OPTIONS** see page 55

Prices do not include GST. Prices and specifications are subject to change without notice.

Crystal

self contained



Electronic controller



Top mounted



16" or 18"
bakery tray compatible



Internal racking with
tray slides



10 Amp power

An Australian made cabinet purpose built for the bakery industry with a choice of a one or two door models with various options. Manufactured specifically to fit 16 inch or 18 inch bakery trays in either a single door or double door, fridge or freezer option.



Advantages

- 43°C ambient rating for hard working environments
- CoolSmart electronic controller for energy efficiency and even temperatures
- Easy clean coved internal liner
- Top mounted refrigeration system for simple maintenance and easy servicing
- Waste heat recovery vaporiser system—no need for external drain
- Threaded castors allow simple leg changeover if required
- Supplied with 20 x 18" x 30" tray slides, 16" x 30" tray slides or 400mm x 600mm tray slides per door (trays and shelves excluded)—size must be advised at time of order
- 75mm spacing between slides
- Can be fitted with shelf stripping and adjustable shelves
- Designed and built to international quality standards for reliability and performance

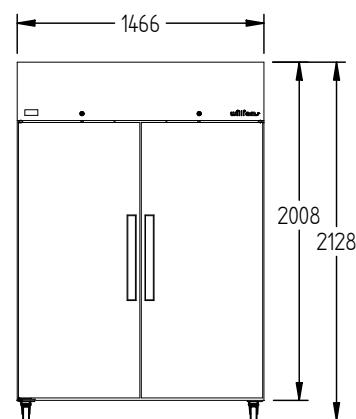
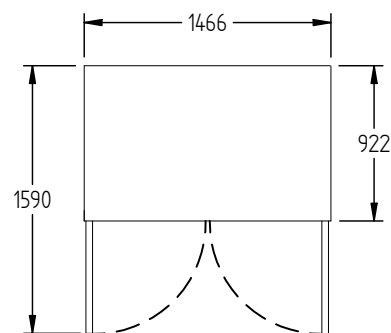
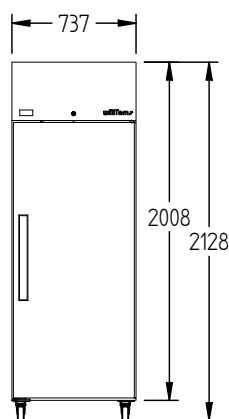
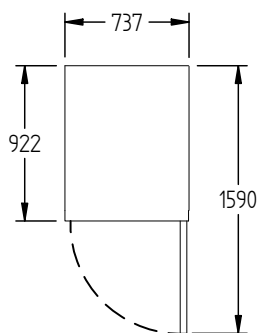
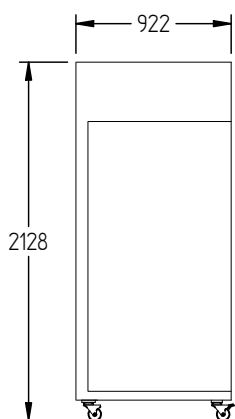

MODEL		1 DOOR		2 DOOR	
R (RETARDER -5°/+3°C)	White	RC1TCB	\$6,087	RC2TCB	\$8,613
L (FREEZER -13°/-21°C)	White	LC1TCB	\$8,509	LC2TCB	\$11,068
R (RETARDER -5°/+3°C)	Stainless steel	RC1TSS	\$7,216	RC2TSS	\$10,185
L (FREEZER -13°/-21°C)	Stainless steel	LC1TSS	\$9,637	LC2TSS	\$12,621

SPECIFICATIONS

CAPACITY LITRES	730	1630
DIMENSIONS - W X D X H (ON 120MM H CASTORS) MM	737 W x 922 D x 2128 H	1466 W x 922 D x 2128 H
WEIGHT UNPACKED (KG)	160	230

STANDARD INCLUSIONS ***

DOOR TYPE	Standard: S (Solid Door)	
FINISH (INTERIOR & EXTERIOR EXCLUDING REAR & UNDER)	S (Stainless Steel) CB (White)	
TRAY SLIDE PAIRS/DOOR (NO TRAYS OR SHELVES SUPPLIED)	20	20

ELECTRICAL

POWER SUPPLY	10 amp	10 amp	
FRIDGE MODELS	RUNNING AMPS	4.0	5.3
FREEZER MODELS	RUNNING AMPS	4.5	5.4

GAS TYPE

REFRIGERANT	FRIDGE MODELS	R134a	R134a
	FREEZER MODELS	R404a	R404a

REFRIGERATION WATTAGES FOR OPTIONAL REMOTE UNITS

FRIDGE MODELS - SOLID DOORS	520 @ -5°C SST	750 @ -5°C SST
FREEZER MODELS - SOLID DOORS	700 @ -30°C SST	1020 @ -30°C SST

*** For **Crystal OPTIONS** see page 55

Prices do not include GST. Prices and specifications are subject to change without notice.

Options

Bakery

Opal Bakery
Garnet Bakery
Crystal



Extra slides



LED lighting to solid doors



Right hand services



Cylindrical locks



Shelves



Locking tabs



Remote



Stainless steel shelves

OPTIONS	OPAL BAKERY		GARNET BAKERY		CRYSTAL	
	2 DOOR	3 DOOR	1 DOOR	2 DOOR	1 DOOR	2 DOOR
430 grade stainless steel rear & under	\$370	\$555	\$295	\$590	\$295	\$590
4622 stainless steel interior & exterior excluding rear and under	\$770	\$1,155	\$450	\$900	\$450	\$900
4622 stainless steel rear & under	\$570	\$855	\$355	\$710	\$355	\$710
430 grade stainless exterior 4622 stainless interior	\$510	\$765	\$295	\$590	\$295	\$590
Cylindrical locks	\$270	\$405	\$135	\$270	\$135	\$270
Locking Tabs	\$60	\$90	\$60	\$90	\$60	\$90
Lights to solid doors	\$155	\$310	\$85	\$175	N/A	N/A
Extra pair of slides	\$110	\$165	\$55	\$110	\$55	\$110
Plastic coated shelves	\$114	\$171	\$57	\$114	\$95	\$160
Stainless steel shelf upgrade (each)	\$390	\$585	\$195	\$390	\$390	\$780
Right hand services	\$215	\$215	N/A	N/A	N/A	N/A
Adjustable legs (150 mm high)	\$60	\$90	\$60	\$60	\$60	\$60
Larger castors (increases to 900 mm work bench height)	\$110	\$110	N/A	N/A	N/A	N/A
Solenoid fitted (remote only)			\$295			
Hand valves fitted (remote only)			\$250			
REMOTE APPLICATION						
Refrigerator (deduct)	-\$185	-\$185	-\$265	-\$330	-\$265	-\$330
Freezer (deduct)	-\$285	-\$285	-\$365	-\$480	-\$365	-\$480

NOTES

- Optional adjustable legs (supplied loose) in lieu of castors adds 30 mm to overall height
- Standard hinge on single door upright models: SD-RHH when facing front of unit
- Optional door hang on single door (must be advised at time of order, new build only)
- Gas Type: Refrigerator—134a: Freezer—404a: Optional Remote (refrigerator and freezer) 404a
- Garnet & Opal Bakery are supplied with 600mm x 400mm tray slides to suit bakers trays per door (trays and shelves excluded)
- Crystal is supplied with 20 x 18" x 30" tray slides or 16" x 30" tray slides or 600mm x 400mm tray slides – size must be advised at time of order

A professional kitchen scene featuring stainless steel preparation counters. The counters are topped with stacks of white plates and have integrated sinks. Below the counters are stainless steel cabinets and drawers, some with the 'williams' brand name visible. The background shows more kitchen equipment and shelving units. The overall lighting is dim, with a pinkish-purple gradient overlay on the right side of the image.

Preparation counters

Jade Sandwich counter

self contained



Electronic controller

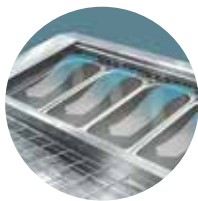

Blown airwell



Removable air ducts



Removable cassette



10 Amp power

Our Australian made and designed sandwich counters are engineered to perform in the harshest environments that kitchens can dish up. They are designed to highlight your fresh ingredients while providing you quick access, a large preparation area and huge storage space for the busiest kitchen.



Advantages

- High ambient rating for hard working environments
- CoolSmart electronic controller for energy efficiency and even temperatures
- Fully enclosed stainless steel well under food pans—prevents food from dropping into cabinet
- Front mounted condenser with removable grill for ease of cleaning
- Square glass canopy
- Polypropylene cutting board (10mm thick)
- One plastic coated shelf per door
- Refrigerated blown air over and under ALL pans—maximises food holding capacity and refrigeration efficiency
- Removable blown air ducts for easy cleaning
- Polycarbonate sliding lids over blown air well
- 4622 grade stainless worktop
- Self closing doors
- Forced air refrigeration system contained in a removable cassette for easy servicing and maintenance
- Waste heat recovery vaporiser system—no need for external drain
- Longer life anti corrosive evaporator coil coating
- Swivel and brake castors
- Threaded castors allow simple leg changeover if required
- Face mounted hinges for plinth mounting
- Designed and built to international quality standards for reliability and performance—HACCP compliant

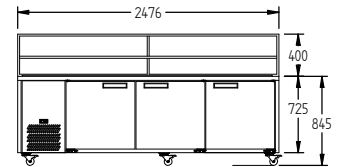
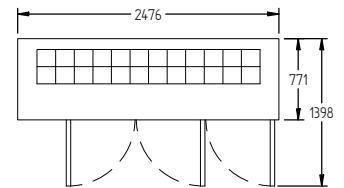
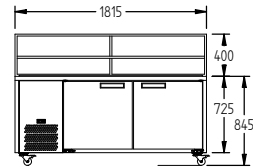
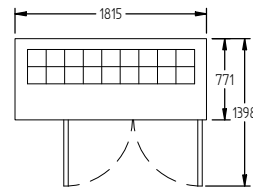
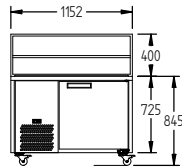
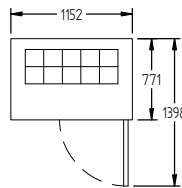
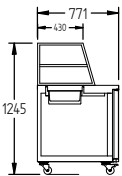

MODEL		1 DOOR		2 DOOR		3 DOOR	
H (REFRIGERATOR +1°/+4°C)	White	HJ1SCBA	\$6,233	HJ2SCBA	\$7,335	HJ3SCBA	\$8,632
H (REFRIGERATOR +1°/+4°C)	Stainless Steel	HJ1SCBASS	\$7,281	HJ2SCBASS	\$9,207	HJ3SCBASS	\$11,438

SPECIFICATIONS

CAPACITY LITRES	250	500	750
GN PANS 100 MM DEEP (INCLUDED)	10 X 1/6	18 X 1/6	24 X 1/6
DIMENSIONS - W X D X H (ON 120MM H CASTORS) MM	1152 W x 771 D x 845 H	1815 W x 771 D x 845 H	2476 W x 771 D x 845 H
WEIGHT UNPACKED (KG)	160	210	240

STANDARD INCLUSIONS ***

DOOR TYPE	Standard: SD (Solid Door) Optional: DR (Drawer)		
FINISH (INTERIOR & EXTERIOR EXCLUDING UNDER. STAINLESS STEEL INTERNAL FLOOR & PREP AREA)	CB (White), CBB (Black), SS (Stainless Steel)		
SHELVES/DOOR	1	1	1

ELECTRICAL

POWER SUPPLY	10 amp	10 amp	10 amp
FRIDGE MODELS	RUNNING AMPS	3.8	4.8

GAS TYPE

REFRIGERANT	SELF CONTAINED	R134a	R134a	R134a
	REMOTE	R404a	R404a	R404a

REFRIGERATION WATTAGES FOR OPTIONAL REMOTE UNITS

REMOTE WATTAGES	600 @ -10°C SST	750 @ -10°C SST	980 @ -10°C SST
-----------------	-----------------	-----------------	-----------------

*** For **Jade Sandwich counter OPTIONS** see page 65

Prices do not include GST. Prices and specifications are subject to change without notice.

Jade Pizza counter

self contained



Electronic controller

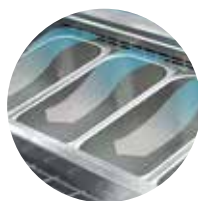

Blown airwell



Removable air ducts



Removable cassette

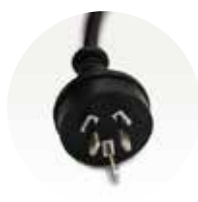

10 Amp power

Our Australian made and designed pizza counters are engineered to perform in the harshest environments that kitchens can dish up. They are designed for quick access to fresh ingredients, combined with a large preparation area and huge storage space for the busiest kitchen.



Advantages

- High ambient rating for hard working environments
- CoolSmart electronic controller for energy efficiency and even temperatures
- Fully enclosed stainless steel well under food pans—prevents food from dropping into cabinet
- Front mounted condenser with removable grill for ease of cleaning
- Raised ergonomically angle pots
- Removable wire grid for easy tray sliding
- One plastic coated shelf per door
- Refrigerated blown air over and under ALL pans—maximises food holding capacity and refrigeration efficiency
- Removable blown air ducts for easy cleaning
- Polycarbonate sliding lids over blown air well
- 4622 grade stainless worktop
- Self closing doors
- Forced air refrigeration system contained in a removable cassette for easy servicing and maintenance
- Waste heat recovery vaporiser system—no need for external drain
- Longer life anti corrosive evaporator coil coating
- Swivel and brake castors
- Threaded castors allow simple leg changeover if required
- Face mounted hinges for plinth mounting
- Designed and built to international quality standards for reliability and performance—HACCP compliant

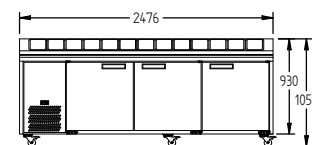
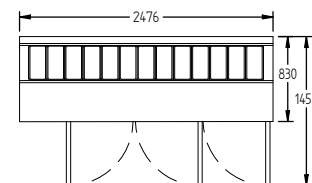
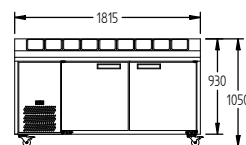
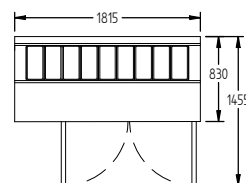
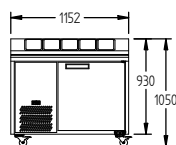
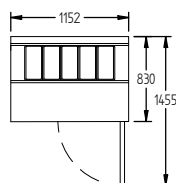
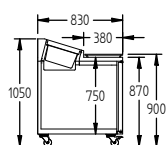

MODEL		1 DOOR		2 DOOR		3 DOOR	
H (REFRIGERATOR +1°/+4°C)	White	HJ1PCBA	\$5,968	HJ2PCBA	\$7,336	HJ3PCBA	\$8,444
H (REFRIGERATOR +1°/+4°C)	Stainless Steel	HJ1PCBASS	\$7,064	HJ2PCBASS	\$9,016	HJ3PCBASS	\$11,022

SPECIFICATIONS

CAPACITY LITRES	400	710	1070
GN PANS 150 MM DEEP (INCLUDED)	5 X 1/3	9 X 1/3	13 X 1/3
DIMENSIONS - W X D X H (ON 120MM H CASTORS) MM	1152 W x 830 D x 870 H	1815 W x 830 D x 870 H	2476 W x 830 D x 870 H
WEIGHT UNPACKED (KG)	160	210	240

STANDARD INCLUSIONS ***

DOOR TYPE	Standard: SD (Solid Door) Optional: DR (Drawer)		
FINISH (INTERIOR & EXTERIOR EXCLUDING UNDER. STAINLESS STEEL INTERNAL FLOOR & PREP AREA)	CB (White), CBB (Black), SS (Stainless Steel)		
SHELVES/DOOR	1	1	1

ELECTRICAL

POWER SUPPLY	10 amp	10 amp	10 amp	
FRIDGE MODELS	RUNNING AMPS	3.8	4.8	5.8

GAS TYPE

REFRIGERANT	SELF CONTAINED	R134a	R134a	R134a
	REMOTE	R404a	R404a	R404a

REFRIGERATION WATTAGES FOR OPTIONAL REMOTE UNITS

REMOTE WATTAGES	600 @ -10°C SST	750 @ -10°C SST	1200 @ -10°C SST
-----------------	-----------------	-----------------	------------------

*** For **Jade Pizza counter OPTIONS** see page 65

Prices do not include GST. Prices and specifications are subject to change without notice.

Banksia

self contained



Electronic controller

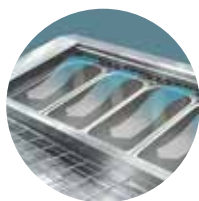

Blown airwell



Removable air ducts



Removable cassette



10 Amp power

Our Australian made and designed Banksia counters are engineered to perform in the harshest environments that kitchens can dish up. They are designed to highlight your fresh ingredients while providing you quick and easy access.



Advantages

- High ambient rating for hard working environments
- CoolSmart electronic controller for energy efficiency and even temperatures
- Fully enclosed stainless steel well under food pans—prevents food from dropping into cabinet
- Square glass canopy with rear sliding polycarbonate covers
- Polypropylene cutting board (10mm thick)
- One plastic coated shelf per door
- Refrigerated blown air over and under ALL pans—maximises food holding capacity and refrigeration efficiency
- Removable blown air ducts for easy cleaning
- Large under counter storage capacity
- 4622 grade stainless worktop
- Self-closing solid doors
- Forced air refrigeration system contained in a removable cassette for easy servicing and maintenance
- Waste heat recovery vaporiser system—no need for external drain
- Longer life anti corrosive evaporator coil coating
- Swivel and brake castors
- Threaded castors allow simple leg changeover if required
- Face mounted hinges for plinth mounting
- Designed and built to international quality standards for reliability and performance—HACCP compliant

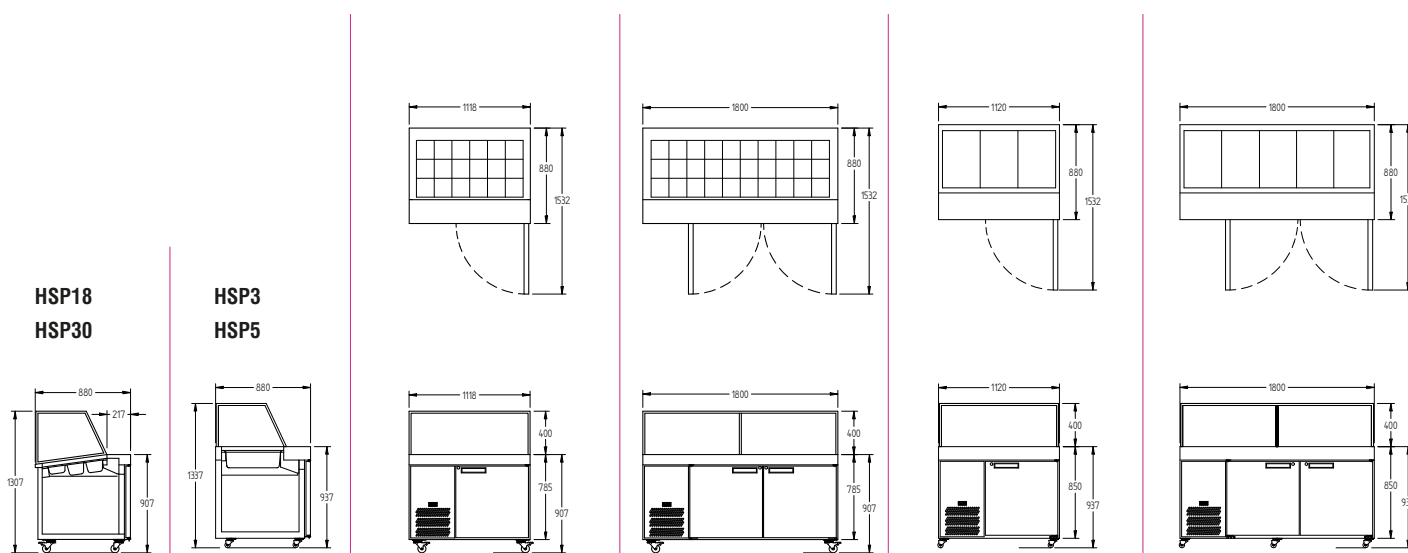

MODEL		1 DOOR - HSP18		2 DOOR - HSP30		1 DOOR - HSP3		2 DOOR - HSP5	
H (REFRIGERATOR +1°/+4°C)	White	HSP18UBA	\$8,369	HSP30UBA	\$9,970	HSP3UBA	\$8,369	HSP5UBA	\$9,970
H (REFRIGERATOR +1°/+4°C)	Stainless Steel	HSP18UBASS	\$9,052	HSP30UBASS	\$11,474	HSP3UBASS	\$9,052	HSP5UBASS	\$11,474

SPECIFICATIONS

CAPACITY LITRES		250	500	250	500
GN PANS (INCLUDED)		18 X 1/6 (6 X 65 mm, 12 X 100 mm deep)	30 X 1/6 (10 X 65 mm, 20 X 100 mm deep)	3 x 1/1 (150 mm deep)	5 x 1/1 (150 mm deep)
DIMENSIONS - W X D X H (ON CASTORS) MM		1118 W x 880 D x 907 H	1800 W x 880 D x 907 H	1120 W x 880 D x 937 H	1800 W x 880 D x 937 H
WEIGHT UNPACKED (KG)		160	210	160	210

STANDARD INCLUSIONS ***

DOOR TYPE

Standard: SD (Solid Door)

FINISH (INTERIOR & EXTERIOR EXCLUDING UNDER. STAINLESS STEEL INTERNAL FLOOR & PREP AREA)

CB (White), CBB (Black), SS (Stainless Steel)

SHELVES/DOOR

1

1

1

1

ELECTRICAL

POWER SUPPLY		10 amp	10 amp	10 amp	10 amp
FRIDGE MODELS	RUNNING AMPS	4.2	5.0	4.2	5.0

GAS TYPE

REFRIGERANT	SELF CONTAINED	R134a	R134a	R134a	R134a
	REMOTE	R404a	R404a	R404a	R404a

REFRIGERATION WATTAGES FOR OPTIONAL REMOTE UNITS

REMOTE WATTAGES		750 @ -10°C SST	980 @ -10°C SST	750 @ -10°C SST	980 @ -10°C SST
-----------------	--	-----------------	-----------------	-----------------	-----------------

*** For **Banksia OPTIONS** see page 65

Prices do not include GST. Prices and specifications are subject to change without notice.

Thermowell

self contained



Digital thermometer



Hinged lid



Accepts a variety of gastronorm pans

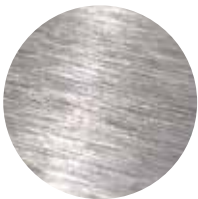

Stainless steel finish



10 Amp power

The Thermowell is a refrigerated prep well, designed to accommodate 1/3 or 1/6 Gastronorm pans. The versatile units can be wall mounted or free-standing. It's also designed with a hinged lid—to stay open during food preparation.



Advantages

- Designed and engineered to operate efficiently in environments up to 32°C
- Digital thermometer and adjustable thermostat
- Stainless steel exterior and interior
- Hinged pan lid (pans excluded)
- Designed to accommodate 1/3 100mm deep Gn pans
- Fitted with rubber feet offering nonslip placement
- Removable unit cover for easy access for servicing and maintenance

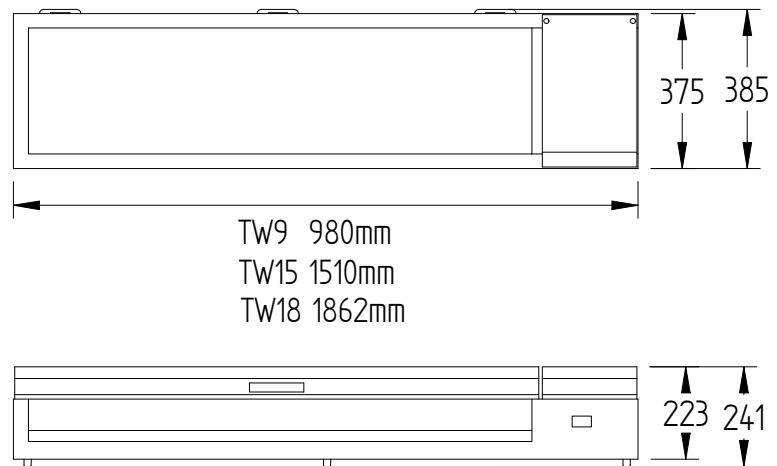
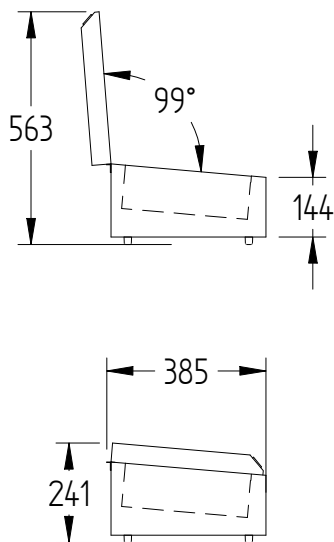

MODEL		TW9		TW15		TW18	
H (REFRIGERATOR +4°/+8°C)	Stainless Steel	TW9	\$1,948	TW15	\$2,153	TW18	\$2,358
SPECIFICATIONS							
CAPACITY (GN PANS EXCLUDED)		4 X 1/3 X 100 mm Gn pans		7 X 1/3 X 100 mm Gn pans		9 X 1/3 X 100 mm Gn pans	
DIMENSIONS - W X D X H MM		980 W x 385 D x 241 H		1510 W x 385 D x 241 H		1862 W x 385 D x 241 H	
WEIGHT UNPACKED (KG)		30		40		50	
FINISH (INTERIOR AND EXTERIOR EXCLUDING UNDER)				SS (Stainless Steel)			
ELECTRICAL							
POWER SUPPLY		10 amp		10 amp		10 amp	
FRIDGE MODELS	RUNNING AMPS	1.3		1.3		1.3	
GAS TYPE							
REFRIGERANT	FRIDGE MODELS	R134a		R134a		R134a	

Prices do not include GST. Prices and specifications are subject to change without notice.

Options

Preparation counters

Jade Sandwich counter

Jade Pizza counter

Banksia

Thermowell



Right-hand services



Larger castors



Black finish



Different pan modules available



Cylindrical locks



Drawers



Locking tabs



Stainless steel shelves

OPTIONS	JADE SC			JADE PC			BANKSIA	
	HJ1SC	HJ2SC	HJ3SC	HJ1PC	HJ2PC	HJ3PC	HSP18/3	HSP30/5
	1 DOOR	2 DOOR	3 DOOR	1 DOOR	2 DOOR	3 DOOR	1 DOOR	2 DOOR
430 grade stainless steel under	\$180	\$240	\$370	\$180	\$240	\$370	\$180	\$240
4622 stainless steel interior & exterior excluding under	\$385	\$770	\$1,155	\$385	\$770	\$1,155	\$385	\$770
4622 stainless steel under	\$285	\$570	\$855	\$285	\$570	\$855	\$285	\$855
Cylindrical locks	\$135	\$270	\$405	\$135	\$270	\$405	\$135	\$270
Locking tabs	\$30	\$60	\$90	\$30	\$60	\$90	\$30	\$60
Light to solid doors	\$155	\$155	\$310	\$155	\$155	\$310	\$155	\$155
Extra plastic coated shelf with clips	\$57	\$114	\$171	\$57	\$114	\$171	\$57	\$114
Stainless steel shelf upgrade (each)	\$195	\$390	\$585	\$195	\$390	\$585	\$195	\$390
Adjustable legs (150 mm high)	\$60	\$60	\$90	\$60	\$60	\$90	\$60	\$60
Without canopy	-\$240	-\$300	-\$360		N/A		-\$240	-\$300
Polypropylene board in lieu of wire crumb grid		N/A		\$64	\$86	\$124		N/A
2 bank full drawer set - 1 set per cabinet only *	N/A	\$1,195	\$1,195	N/A	\$1,195	\$1,195		N/A
Side venting			INCL				\$225	
RH services (services to right hand side)				\$215				
2 x 1/6 Gn pan module with pans (each)				\$75				
3 x 1/9 Gn pan module with pans (each)				\$90				
Larger castors (900 mm work bench height approx)				\$110				
Solenoid fitted (remote only)				\$295				
Hand valves fitted (remote only)				\$250				
Remote application in self contained body (deduct)				-\$185				

NOTES

- 150 mm deep pans are included in Pizza Prep (PC) cabinet
- 100 mm deep pans are included in Sandwich Prep (SC) cabinet
- 150 mm deep pans are included in HSP3 & HSP5. Varying pan depths in HSP18 & HSP30 cabinets
- Height includes castors. Option legs (supplied loose) in lieu of castors adds 30 mm to overall height
- *Check configuration for drawers before specifying



General counters + back bars

Boronia

self contained



Electronic controller



Front breathing



Removable refrigeration cassette



LED lighting



10 Amp power

The Australian made Boronia self-contained cabinets have been designed to operate efficiently with the demands of busy venues. The units have been engineered to maintain temperature during the continual opening and closing of doors, as when products are taken out, or stock is replenished.

The units are available in one to four door counters, manufactured in stainless steel or hardwearing black coated steel. The glass door units with LED lighting ensure an attractive display, while adjustable shelves enable different sized bottles and cans to be stored with flexibility.



Advantages

- Designed for 43°C ambient environment
- Adjustable electronic controller with digital temperature display
- Front breathing ventilation
- Removable refrigeration cassette
- Forced air refrigeration system contained in a removable cassette
- for easy service and maintenance
- Optimised ducted air flow
- Auto defrost utilising waste heat recovery vaporiser
- Two adjustable plastic coated shelves per door
- Anti-corrosive evaporator coil coating
- Heavy duty swivel and brake castors (legs optional)
- On/off switch for internal lights (glass door only)
- Fitted with triple glazed self closing doors
- Cool white LED strip lighting
- Optional triple glazed heated glass doors
- Choice of optional warm LED lights or dimmable
- Face mounted hinges (plinth mount ready)

General counters + back bars

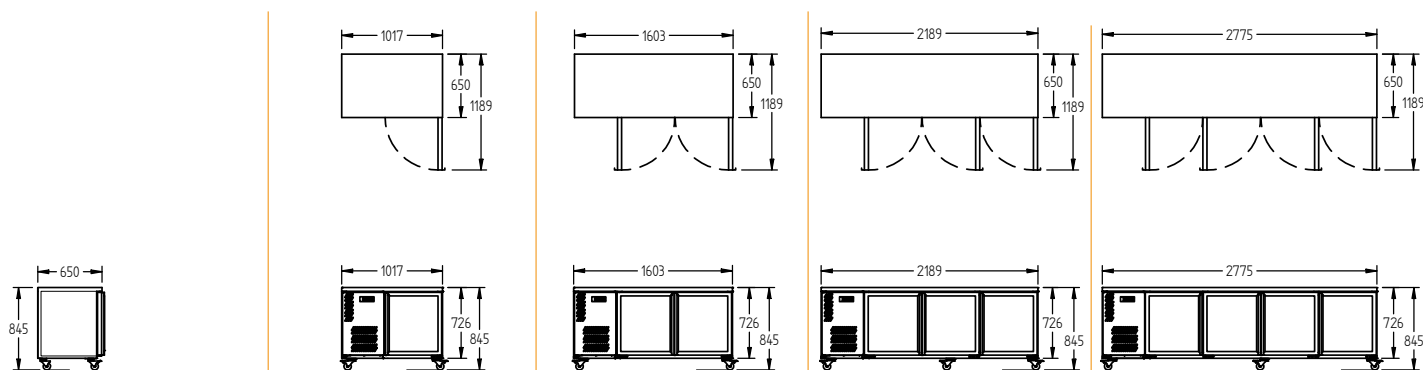

MODEL		1 DOOR		2 DOOR		3 DOOR		4 DOOR	
H (Refrigerator +1°/+4°C)	Black, Glass door	HB1UGB	\$4,129	HB2UGB	\$5,158	HB3UGB	\$6,399	HB4UGB	\$7,829
H (Refrigerator +1°/+4°C)	Black, Solid door	HB1USB	\$4,129	HB2USB	\$5,158	HB3USB	\$6,399	HB4USB	\$7,829
H (Refrigerator +1°/+4°C)	Stainless Steel, Glass door	HB1UGS	\$4,593	HB2UGS	\$5,784	HB3UGS	\$6,967	HB4UGS	\$8,771
H (Refrigerator +1°/+4°C)	Stainless Steel, Solid door	HB1USS	\$4,593	HB2USS	\$5,784	HB3USS	\$6,967	HB4USS	\$8,771

SPECIFICATIONS

CAPACITY LITRES	180	360	560	760
DIMENSIONS - W X D X H (ON 120MM H CASTORS) MM	1017 W x 650 D x 845 H	1603 W x 650 D x 845 H	2189 W x 650 D x 845 H	2775 W x 650 D x 845 H
WEIGHT UNPACKED (KG)	110	130	150	170

STANDARD INCLUSIONS ***

DOOR TYPE	Standard: G (Glass door), S (Solid door)			
FINISH	B (Black) with stainless steel countertop and internal floor or S (Stainless steel) interior and exterior excluding rear and under			
SHELVES/DOOR	2	2	2	2

ELECTRICAL

POWER SUPPLY	10 amp	10 amp	10 amp	10 amp	
FRIDGE MODELS - GLASS DOORS	RUNNING AMPS	2.1	2.7	2.9	3.5
FRIDGE MODELS - SOLID DOORS	RUNNING AMPS	2.1	2.7	2.9	3.5

GAS TYPE

REFRIGERANT	FRIDGE MODELS	R134a	R134a	R134a	R134a
--------------------	----------------------	-------	-------	-------	-------

*** For **Boronia self contained OPTIONS** see page 85

Prices do not include GST. Prices and specifications are subject to change without notice.

Boronia

remote



Electronic controller



Three-sided service connection



Easy access service compartment



LED lighting



10 Amp power

The Australian made Boronia remote cabinets have been designed to operate efficiently with the demands of busy venues. The units have been engineered to maintain temperature during the continual opening and closing of doors, as when products are taken out, or stock is replenished.

The units are available in one to four door counters, manufactured in stainless steel or hardwearing black coated steel. The glass door units with LED lighting ensure an attractive display, while adjustable shelves enable different sized bottles and cans to be stored with flexibility.



Advantages

- Designed for 43°C ambient environment
- Adjustable electronic controller with digital temperature display
- Fitted with evaporator, Tx valve, digital controller, three pin plug and condensate drain
- Optimised ducted air flow
- Two adjustable plastic coated shelves per door
- Large display capacity
- On castors for mobility—legs are supplied with cabinet
- Anti-corrosive evaporator coil coating
- On/off switch for internal lights (glass door only)
- Fitted with triple glazed self closing doors
- Cool white LED strip lighting
- Optional triple glazed heated glass doors
- Choice of optional warm LED lights or dimmable
- Face mounted hinges (plinth mount ready)
- Easy connection access (three sides)

General counters + back bars

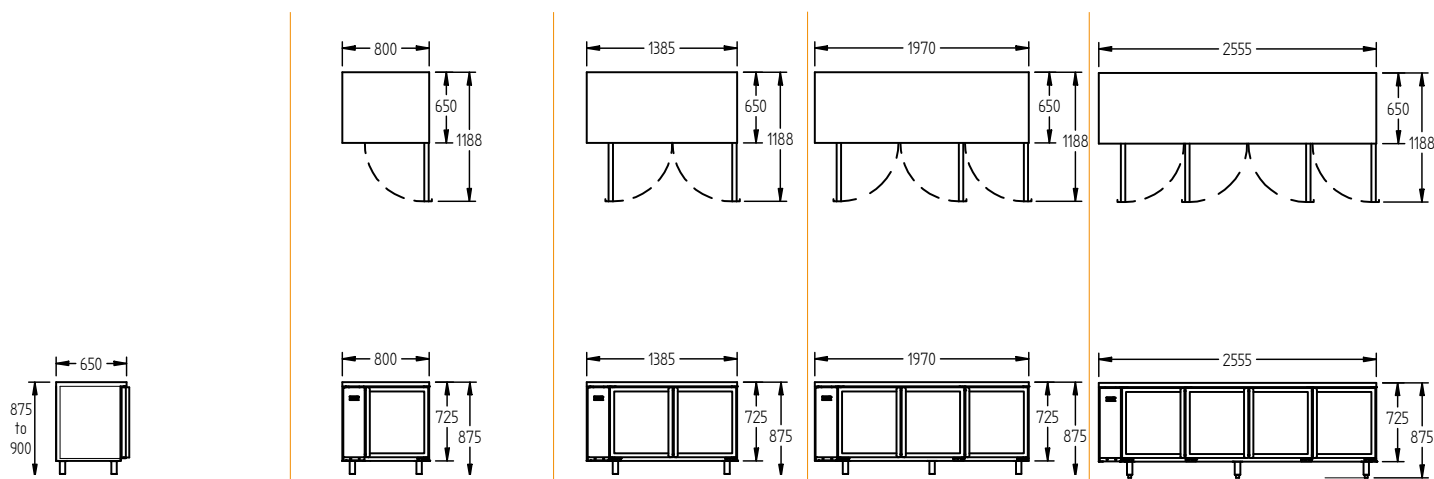

MODEL		1 DOOR	2 DOOR	3 DOOR	4 DOOR				
H (REFRIGERATOR +1°/+4°C)	Black, Glass door	HB1RGB	\$3,565	HB2RGB	\$3,943	HB3RGB	\$5,296	HB4RGB	\$6,980
H (REFRIGERATOR +1°/+4°C)	Black, Solid door	HB1RSB	\$3,565	HB2RSB	\$3,943	HB3RSB	\$5,296	HB4RSB	\$6,980
H (REFRIGERATOR +1°/+4°C)	Stainless Steel, Glass door	HB1RGS	\$4,083	HB2RGS	\$4,624	HB3RGS	\$5,781	HB4RGS	\$7,970
H (REFRIGERATOR +1°/+4°C)	Stainless Steel, Solid door	HB1RSS	\$4,083	HB2RSS	\$4,624	HB3RSS	\$5,781	HB4RSS	\$7,970

SPECIFICATIONS

CAPACITY LITRES	180	360	560	760
DIMENSIONS - W X D X H (ON 150MM H LEGS) MM	800 W x 650 D x 875 H	1385 W x 650 D x 875 H	1970 W x 650 D x 875 H	2555 W x 650 D x 875 H
WEIGHT UNPACKED (KG)	100	120	140	160

STANDARD INCLUSIONS ***

DOOR TYPE	Standard: G (Glass door), S (Solid door)			
FINISH	B (Black) with stainless steel countertop and internal floor or S (Stainless steel) interior and exterior excluding rear and under			
SHELVES/DOOR	2	2	2	2

ELECTRICAL

POWER SUPPLY	10 amp	10 amp	10 amp	10 amp	
FRIDGE MODELS - GLASS DOORS	RUNNING AMPS	0.6	0.6	1.0	1.6
FRIDGE MODELS - SOLID DOORS	RUNNING AMPS	0.6	0.6	1.0	1.6

GAS TYPE

REFRIGERANT	R404a	R404a	R404a	R404a
--------------------	-------	-------	-------	-------

REFRIGERATION WATTAGES FOR STANDARD REMOTE UNITS

REMOTE WATTAGES	300 @ -5°C SST	560 @ -5°C SST	690 @ -5°C SST	850 @ -5°C SST
------------------------	----------------	----------------	----------------	----------------

*** For **Boronia remote OPTIONS** see page 85

Prices do not include GST. Prices and specifications are subject to change without notice.

Cameo

self contained



Electronic controller



Front breathing



Removable refrigeration cassette

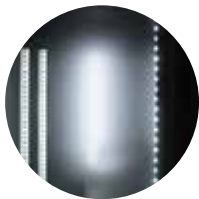

LED lighting

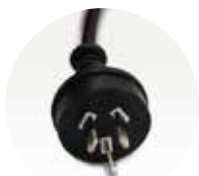

10 Amp power

The Australian made Cameo self-contained cabinets have been designed to operate efficiently with the demands of busy venues. The units have been engineered to maintain temperature during the continual opening and closing of doors, as when products are taken out, or stock is replenished.

The units are available in one to four door counters, manufactured in stainless steel or hardwearing black coated steel. The glass door units with LED lighting ensure an attractive display, while adjustable shelves enable different sized bottles and cans to be stored with flexibility.



Advantages

- Designed for 43°C ambient environment
- Adjustable electronic controller with digital temperature display
- Front breathing ventilation
- Forced air refrigeration system contained in a removable cassette for easy service and maintenance
- Optimised ducted air flow
- Auto defrost utilising waste heat recovery vapouriser
- Two adjustable plastic coated shelves per door
- Anti-corrosive evaporator coil coating
- Heavy duty swivel and brake castors (legs optional)
- On/off switch for internal lights (glass door only)
- Fitted with triple glazed self closing doors
- Cool white LED lighting
- Optional triple glazed heated glass doors
- Choice of optional warm LED lights or dimmable
- Face mounted hinges (plinth mount ready)

General counters + back bars

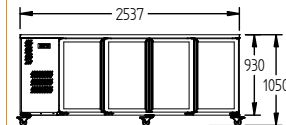
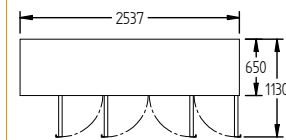
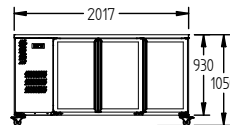
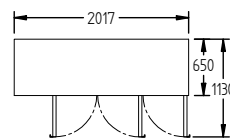
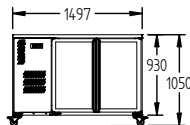
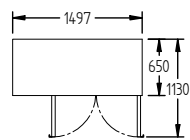
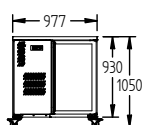
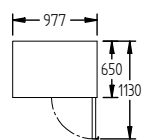
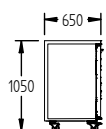

MODEL		1 DOOR		2 DOOR		3 DOOR		4 DOOR	
H (REFRIGERATOR +1°/+4°C)	Black, Glass door	HC1UGB	\$4,352	HC2UGB	\$5,055	HC3UGB	\$6,310	HC4UGB	\$7,932
H (REFRIGERATOR +1°/+4°C)	Black, Solid door	HC1USB	\$4,352	HC2USB	\$5,055	HC3USB	\$6,310	HC4USB	\$7,932
H (REFRIGERATOR +1°/+4°C)	Stainless Steel, Glass door	HC1UGS	\$4,862	HC2UGS	\$6,053	HC3UGS	\$7,720	HC4UGS	\$9,395
H (REFRIGERATOR +1°/+4°C)	Stainless Steel, Solid door	HC1USS	\$4,862	HC2USS	\$6,053	HC3USS	\$7,720	HC4USS	\$9,395

SPECIFICATIONS

CAPACITY LITRES	200	420	640	870
DIMENSIONS - W X D X H (ON 120MM H CASTORS) MM	977 W x 650 D x 1050 H	1497 W x 650 D x 1050 H	2017 W x 650 D x 1050 H	2537 W x 650 D x 1050 H
WEIGHT UNPACKED (KG)	160	180	200	230

STANDARD INCLUSIONS ***

DOOR TYPE	Standard: G (Glass door), S (Solid door)			
FINISH	B (Black) with stainless steel countertop and internal floor or S (Stainless steel) interior and exterior excluding rear and under			
SHELVES/DOOR	2	2	2	2

ELECTRICAL

POWER SUPPLY	10 amp	10 amp	10 amp	10 amp	
FRIDGE MODELS - GLASS DOORS	RUNNING AMPS	2.1	2.7	2.9	3.5
FRIDGE MODELS - SOLID DOORS	RUNNING AMPS	2.1	2.7	2.9	3.5

GAS TYPE

REFRIGERANT	FRIDGE MODELS	R134a	R134a	R134a	R134a
-------------	---------------	-------	-------	-------	-------

*** For Cameo self contained **OPTIONS** see page 85

Prices do not include GST. Prices and specifications are subject to change without notice.

Cameo

remote

1yr
PARTS



Electronic controller



Three-sided service connection



Easy access service compartment



LED lighting



10 Amp power

The Australian made Cameo remote cabinets have been designed to operate efficiently with the demands of busy venues. The units have been engineered to maintain temperature during the continual opening and closing of doors, as when products are taken out, or stock is replenished.

The units are available in one to five door counters, manufactured in stainless steel or hardwearing black coated steel. The glass door units with LED lighting ensure an attractive display, while adjustable shelves enable different sized bottles and cans to be stored with flexibility.



Advantages

- Designed for 43°C ambient environment
- Adjustable electronic controller with digital temperature display
- Fitted with evaporator, Tx valve, digital controller, three pin plug and condensate drain
- Optimised ducted air flow
- Two adjustable plastic coated shelves per door
- Large display capacity
- On castors for mobility—legs are supplied with cabinet
- Anti-corrosive evaporator coil coating
- On/off switch for internal lights (glass door only)
- Fitted with triple glazed self-closing doors
- Cool white LED lighting
- Optional triple glazed heated glass doors
- Choice of optional warm LED lights or dimmable
- Face mounted hinges (plinth mount ready)
- Easy connection access (three sides)

General counters + back bars

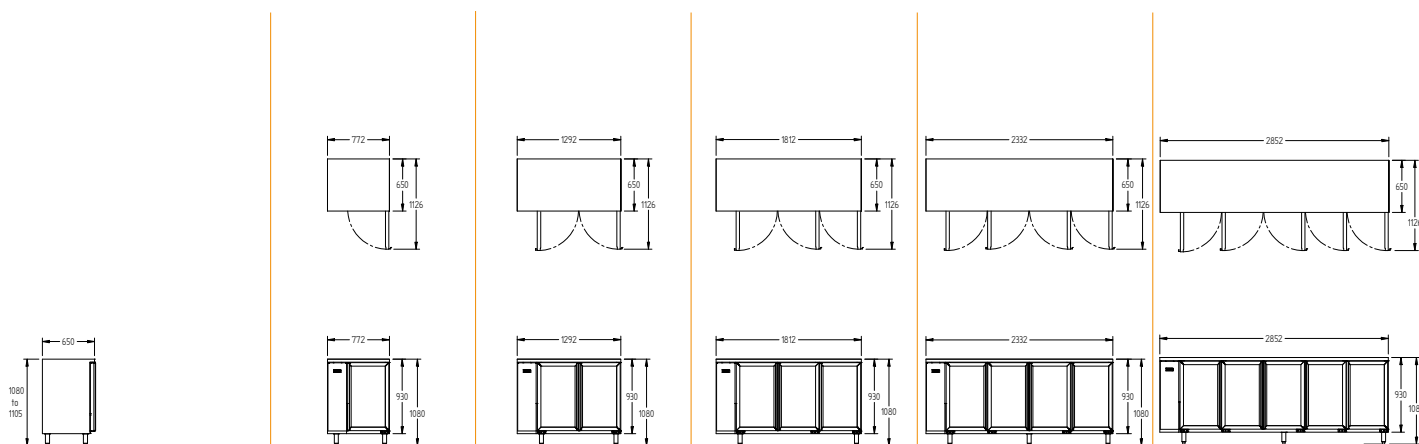

MODEL	1 DOOR		2 DOOR		3 DOOR		4 DOOR		5 DOOR	
H (REFRIGERATOR +1°/+4°C) Black, Glass door	HC1RGB	\$3,656	HC2RGB	\$4,035	HC3RGB	\$5,079	HC4RGB	\$6,702	HC5RGB	\$8,217
H (REFRIGERATOR +1°/+4°C) Black, Solid door	HC1RSB	\$3,656	HC2RSB	\$4,035	HC3RSB	\$5,079	HC4RSB	\$6,702	HC5RSB	\$8,217
H (REFRIGERATOR +1°/+4°C) Stainless Steel, Glass door	HC1RGS	\$4,704	HC2RGS	\$5,299	HC3RGS	\$6,439	HC4RGS	\$8,176	HC5RGS	\$9,799
H (REFRIGERATOR +1°/+4°C) Stainless Steel, Solid door	HC1RSS	\$4,704	HC2RSS	\$5,299	HC3RSS	\$6,439	HC4RSS	\$8,176	HC5RSS	\$9,799

SPECIFICATIONS

CAPACITY LITRES	200	420	640	870	1100
DIMENSIONS - W X D X H (ON 150MM H LEGS) MM	772 W x 650 D x 1080 H	1292 W x 650 D x 1080 H	1812 W x 650 D x 1080 H	2332 W x 650 D x 1080 H	2852 W x 650 D x 1080 H
WEIGHT UNPACKED (KG)	120	170	190	220	260

STANDARD INCLUSIONS ***

DOOR TYPE	Standard: G (Glass door), S (Solid door)				
FINISH	B (Black) with stainless steel countertop and internal floor or S (Stainless steel) interior and exterior excluding rear and under				
SHELVES/DOOR	2	2	2	2	2

ELECTRICAL

POWER SUPPLY	10 amp	10 amp	10 amp	10 amp	10 amp	
FRIDGE MODELS - GLASS DOORS	RUNNING AMPS	0.7	0.7	1.0	1.3	1.7
FRIDGE MODELS - SOLID DOORS	RUNNING AMPS	0.7	0.7	1.0	1.3	1.7

GAS TYPE

REFRIGERANT	R404a	R404a	R404a	R404a	R404a
--------------------	-------	-------	-------	-------	-------

REFRIGERATION WATTAGES FOR STANDARD REMOTE UNITS

REMOTE WATTAGES	350 @ -5°C SST	650 @ -5°C SST	750 @ -5°C SST	900 @ -5°C SST	1300 @ -5°C SST
------------------------	----------------	----------------	----------------	----------------	-----------------

*** For **Cameo remote OPTIONS** see page 85

Prices do not include GST. Prices and specifications are subject to change without notice.

Glass Chiller

self contained



Electronic controller



Front breathing



Suits standard glass racks

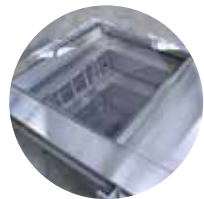

Polycarbonate night lid



10 Amp power

Australian designed and constructed, the Glass Chiller self-contained model has been engineered to rapidly chill beer glasses for efficient, quick bar service. Available in one and two door models with spring and shelf loading options.



Advantages

- Designed for 43°C ambient environment
- Adjustable electronic controller with digital temperature display
- Forced air refrigeration system
- Auto defrost
- GC1U and GC2U—Spring loaded lifting mechanism or adjustable shelves accommodates 355 mm x 355 mm or 355 mm x 431 mm baskets
- Polycarbonate night lid
- GC15U and GC25U—Spring loaded lifting mechanism or adjustable shelves accommodates 500 mm x 500 mm baskets
- Shelf model fitted with two plastic coated shelves per door
- Self-closing triple-glazed doors
- On castors (150mm adjustable legs are an optional extra)
- Face mounted hinges (plinth mount ready)

General counters + back bars

**GC1U
GC2U**

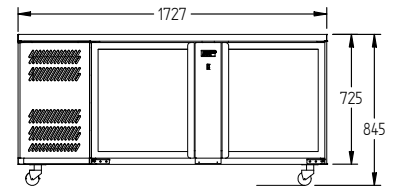
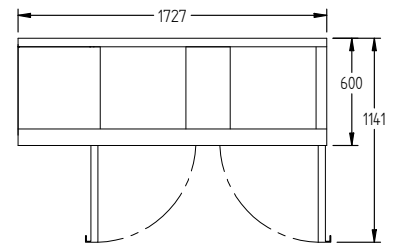
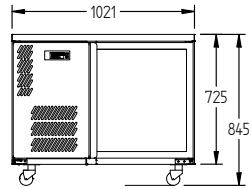
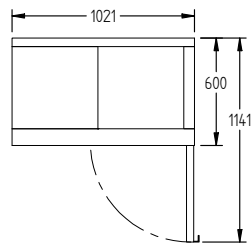
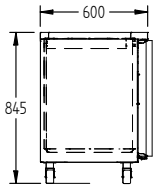

**GC15U
GC25U**

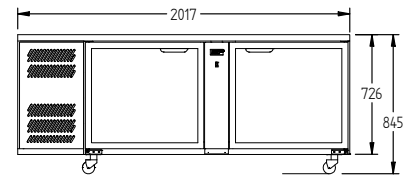
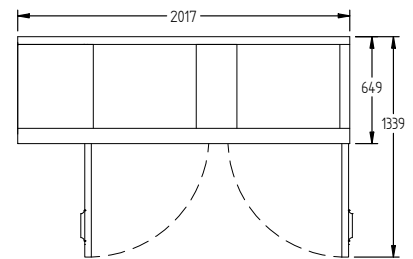
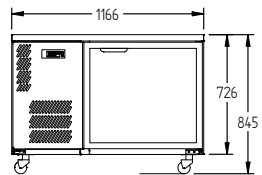
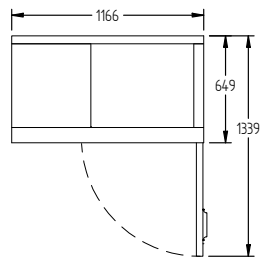
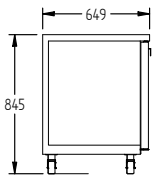

MODEL		1 DOOR	2 DOOR	
H (REFRIGERATOR +1°/+4°C)	Shelf Load	GC1UGD	\$5,414	
H (REFRIGERATOR +1°/+4°C)	Spring Load	GC1UGDSL	\$6,109	
H (REFRIGERATOR +1°/+4°C)	Shelf Load - 500 x 500 baskets	GC15UGD	\$6,080	
H (REFRIGERATOR +1°/+4°C)	Spring Load - 500 x 500 baskets	GC15UGDSL	\$6,776	
			GC2UGD	\$6,949
			GC2UGDSL	\$7,951
			GC25UGD	\$8,281
			GC25UGDSL	\$9,284

SPECIFICATIONS

CAPACITY - BASKET/DOOR (NOT INCLUDED) (BASED ON 150MM H GLASSES)	3 Baskets	3 Baskets
DIMENSIONS - W X D X H (GC1U & GC2U) (ON 120MM H CASTORS) MM	1021 W x 600 D x 845 H	1727 W x 600 D x 845 H
DIMENSIONS - W X D X H (GC15U & GC25U) (ON 120MM H CASTORS) MM (500 X 500 BASKETS)	1166 W x 649 D x 845 H	2017 W x 649 D x 845 H
WEIGHT UNPACKED (KG)	100	140

STANDARD INCLUSIONS ***

DOOR TYPE	Standard: GD (Glass Door)	
FINISH (INTERIOR AND EXTERIOR EXCLUDING REAR AND UNDER)	SS (Stainless Steel)	
SHELVES/DOOR - SHELF LOAD MODEL ONLY	2	2

ELECTRICAL

POWER SUPPLY	10 amp	10 amp
RUNNING AMPS	3.6	4.0

GAS TYPE

REFRIGERANT	R134a	R134a
--------------------	-------	-------

*** For **Glass Chiller OPTIONS** see page 85

Prices do not include GST. Prices and specifications are subject to change without notice.

Glass Chiller

remote

1yr
PARTS



Electronic controller



Easy access
service compartment

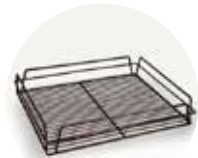

Suits standard
glass racks

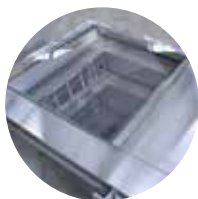

Polycarbonate night lid



10 Amp power

Australian designed and constructed, the Glass Chiller remote fridge models have been engineered to rapidly chill beer glasses for efficient, quick bar service. Available in one and two door models with spring and shelf loading options.



Advantages

- Designed for 43°C ambient environment
- Adjustable electronic controller with digital temperature display
- Forced air refrigeration system
- Fitted with evaporator, TX valve, controller, fitted plug, junction box and condensate drain
- GC1R and GC2R—Spring loaded lifting mechanism or adjustable shelves accommodates 355 mm x 355 mm or 355 mm x 431 mm baskets
- Polycarbonate night lid
- GC15R and GC25R—Spring loaded lifting mechanism or adjustable shelves accommodates 500 mm x 500 mm baskets
- Shelf model fitted with two plastic coated shelves per door
- Self-closing triple glazed doors with easy to clean handles On castors for mobility—legs are supplied with cabinet
- Face mounted hinges (plinth mount ready)

General counters + back bars

**GC1R
GC2R**

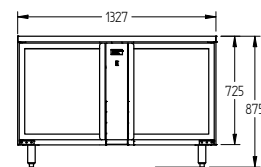
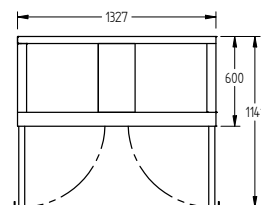
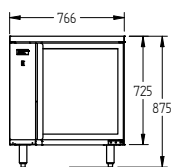
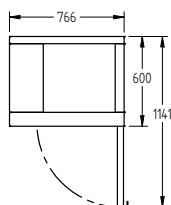
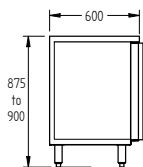

**GC15R
GC25R**

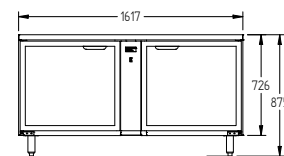
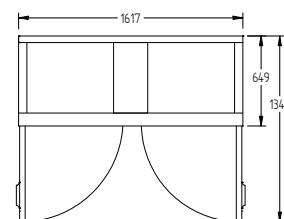
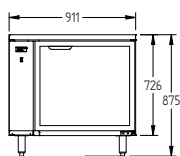
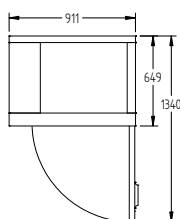
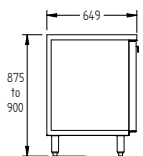

MODEL		1 DOOR	2 DOOR
H (REFRIGERATOR +1°/+4°C)	Shelf Load	GC1RGD	GC2RGD
		\$3,973	\$5,322
H (REFRIGERATOR +1°/+4°C)	Spring Load	GC1RGDSL	GC2RGDSL
		\$4,549	\$5,795
H (REFRIGERATOR +1°/+4°C)	Shelf Load - 500 x 500 baskets	GC15RGD	GC25RGD
		\$4,640	\$6,655
H (REFRIGERATOR +1°/+4°C)	Spring Load - 500 x 500 baskets	GC15RGDSL	GC25RGDSL
		\$5,215	\$7,128

SPECIFICATIONS

CAPACITY - BASKETS/DOOR (NOT INCLUDED) (BASED ON 150MM H GLASSES)	3 Baskets	3 Baskets
DIMENSIONS - W X D X H (GC1R & GC2R) (ON 150MM H LEGS) MM	766 W x 600 D x 875 H	1327 W x 600 D x 875 H
DIMENSIONS - W X D X H (GC15R & GC25R) (ON 150MM H LEGS) MM (500 X 500 BASKETS)	911 W x 649 D x 875 H	1617 W x 649 D x 875 H
WEIGHT UNPACKED (KG)	60	100

STANDARD INCLUSIONS ***

DOOR TYPE	Standard: GD (Glass Door)
FINISH (INTERIOR AND EXTERIOR EXCLUDING REAR AND UNDER)	SS (Stainless Steel)
SHELVES/DOOR - SHELF LOAD MODEL ONLY	2

ELECTRICAL

POWER SUPPLY	10 amp	10 amp
RUNNING AMPS	0.4	0.5

GAS TYPE

REFRIGERANT	R404a	R404a
--------------------	-------	-------

REFRIGERATION WATTAGES FOR STANDARD REMOTE UNITS

REMOTE WATTAGES	570 @ -5° C SST	750 @ -5° C SST
------------------------	-----------------	-----------------

*** For **Glass Chiller OPTIONS** see page 85

Prices do not include GST. Prices and specifications are subject to change without notice.

Glass Chiller slimline

remote

1yr
PARTS



Electronic controller



Easy access
service compartment

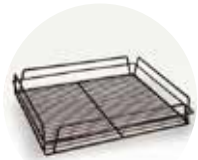

Suits standard
glass racks



Top sliding
polycarbonate lid



10 Amp power

Australian designed and constructed, the Glass Chiller slimline remote model has been engineered to fit into common tight spaces. The unit rapidly chills beer glasses for efficient quick bar service. Available in one door models with a easy access from above via a sliding polycarbonate lid.



Advantages

- Designed for 43°C ambient environment
- Adjustable electronic controller with digital temperature display
- Forced air refrigeration system
- Fitted with evaporator, Tx valve, controller, fitted plug, junction box and condensate drain
- 4622 grade stainless interior and exterior including rear and under
- 3 x adjustable tray slides
- Shelves accommodates 355 mm x 355 mm or 355 mm x 431 mm baskets
- Self-closing triple glazed glass door
- 260mm D x 375 mm W polycarbonate slide top lid with breaker strips fitted
- Removable rear cover—when drink pythons need to run behind the unit
- On castors for mobility—legs are supplied with cabinet
- Face mounted hinges (plinth mount ready)

General counters + back bars

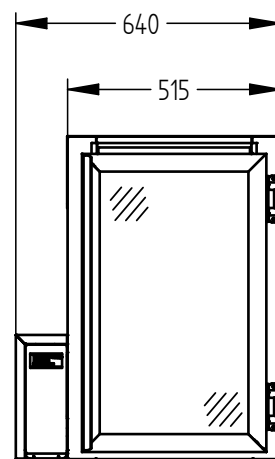
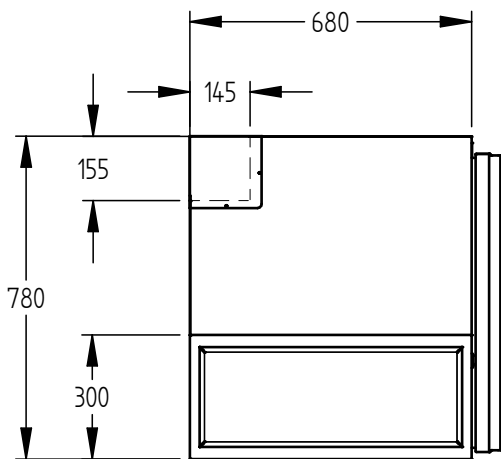
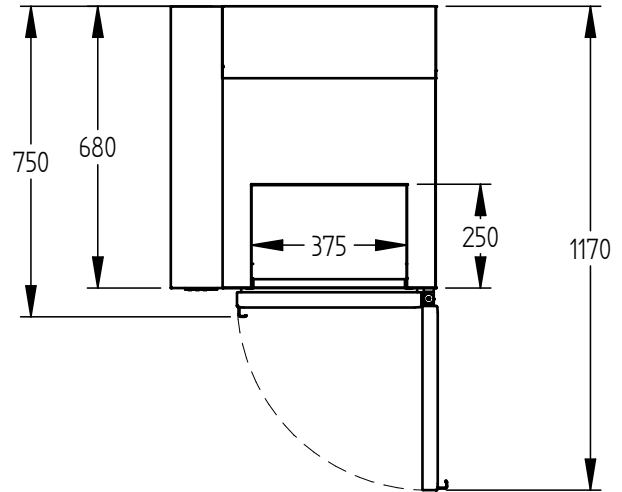

MODEL		1 DOOR	
H (REFRIGERATOR +1°/+4°C)	Tray slide load - Left hand services	FGC1-L	\$4,715
H (REFRIGERATOR +1°/+4°C)	Tray slide load - Right hand services	FGC1-R	\$4,935

SPECIFICATIONS

CAPACITY - BASKETS/DOOR (NOT INCLUDED) (BASED ON 150MM H GLASSES)	3 Baskets
DIMENSIONS - W X D X H (W INCLUDES 125MM W X 300MM H SIDE MOUNTED SERVICE COMPARTMENT) (H IS BODY HEIGHT) MM	640 W x 750 D x 780 H
WEIGHT UNPACKED (KG)	60

STANDARD INCLUSIONS ***

DOOR TYPE	Standard: GD (Glass Door)
FINISH (304 GRADE STAINLESS STEEL INTERIOR AND EXTERIOR INCLUDING REAR AND UNDER)	SS (Stainless Steel)
TRAY SLIDES (NO SHELVES SUPPLIED)	3

ELECTRICAL

POWER SUPPLY	10 amp
RUNNING AMPS	0.4

GAS TYPE

REFRIGERANT	R404a
-------------	-------

REFRIGERATION WATTAGES FOR STANDARD REMOTE UNITS

REMOTE WATTAGES	300 @ -5° C SST
-----------------	-----------------

Bottle Cooler

self contained



Electronic controller



Front breathing



Cylindrical locks



Low noise design



10 Amp power

The Bottle Cooler model is available as a one, two or three door with 895 mm height or 800 mm height. The unit features a stainless steel exterior, mirror stainless interior, and is capable of storing up to 278 x 330 mL bottles at 4°C to 10°C. The units are self-contained and are great in a small sized venue where space is a premium.



Advantages

- Designed for 32°C ambient environment
- Forced air refrigeration system
- Front breathing refrigeration system
- Adjustable electronic controller with digital temperature display
- Two adjustable shelves per door
- Cylindrical locks
- Self-closing double glazed, argon gas filled doors
- On levelling feet—roller castor to rear
- On/off switch for interior light

General counters + back bars

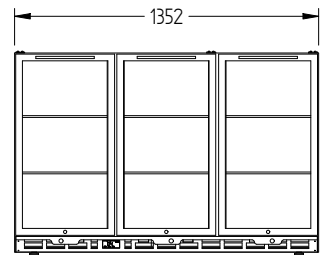
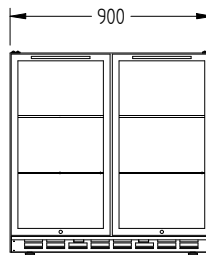
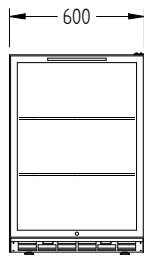
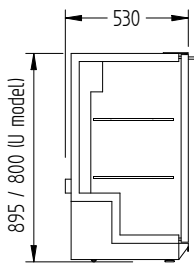

MODEL		1 DOOR		2 DOOR		3 DOOR	
H (REFRIGERATOR +4°/+10°C)	Stainless Steel	BC1SS	\$3,456	BC2SS	\$5,066	BC3SS	\$6,333
H (REFRIGERATOR +4°/+10°C)	Stainless Steel - 800 mm high	BC1SS-80	\$3,456	BC2SS-80	\$5,066	BC3SS-80	\$6,333

SPECIFICATIONS

CAPACITY LITRES - BC	152	238	368
CAPACITY LITRES - BC-80	130	204	315
DIMENSIONS - W X D X H (BC) MM	600 W x 530 D x 895 H	900 W x 530 D x 895 H	1350 W x 530 D x 895 H
DIMENSIONS - W X D X H (BC-80) MM	600 W x 530 D x 800 H	900 W x 530 D x 800 H	1350 W x 530 D x 800 H
WEIGHT UNPACKED (KG)	60	90	120
DOOR TYPE	Standard: GD (Glass Door)		
FINISH (INTERIOR AND EXTERIOR EXCLUDING REAR AND UNDER)	SS (Stainless Steel)		
SHELVES/DOOR	2	2	2

ELECTRICAL

POWER SUPPLY	10 amp	10 amp	10 amp
RUNNING AMPS	1.8	2.0	2.4

GAS TYPE

REFRIGERANT	R134a	R134a	R134a
-------------	-------	-------	-------

Prices do not include GST. Prices and specifications are subject to change without notice.

Wine Cabinet

self contained



Electronic controller



Front breathing



Cylindrical locks



Low noise design

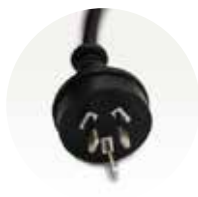

10 Amp power

The upright Wine Cabinet has been designed with industrial standard, cooling performance and reliability. Its contemporary and stylish design complements all modern interior design. The units are available in one or two door models with eye-catching, internal diamond racking.



Advantages

- Designed for 32°C ambient environment
- Adjustable electronic controller with digital temperature display
- Forced air refrigeration system
- Front breathing refrigeration system
- Auto defrost utilising waste heat recovery vaporiser
- Diamond racking for storing bottles
- On/off switch for internal lights
- Cylindrical locks
- Self-closing double glazed argon gas filled doors
- On levelling feet—roller castor to rear
- One and two door models available

General counters + back bars

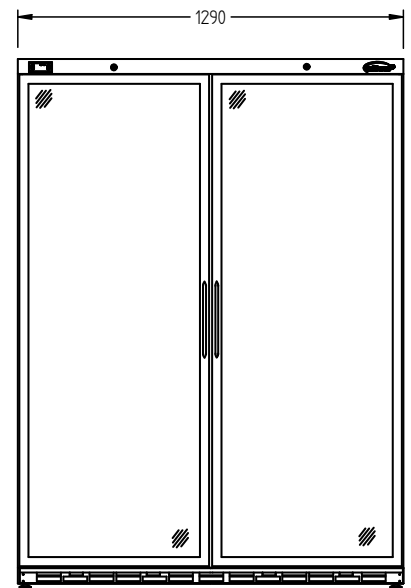
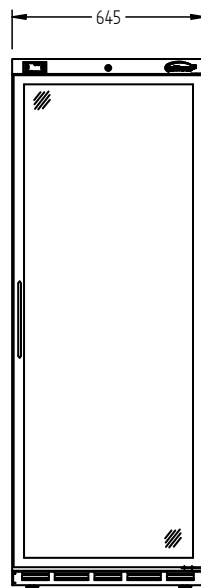
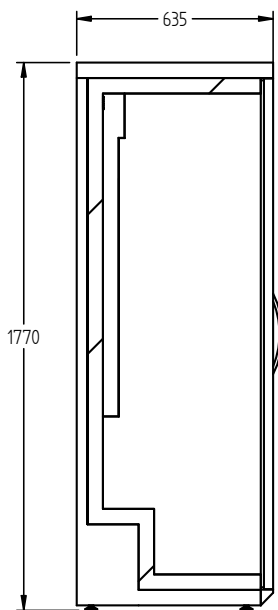

MODEL		1 DOOR		2 DOOR
H (REFRIGERATOR +4°/+22°C)	Stainless Steel, 1 Door	BC95W-DR	\$9,101	—
H (REFRIGERATOR +4°/+22°C)	Stainless Steel, 2 Door	—	—	BC200W-DR \$13,212
SPECIFICATIONS				
CAPACITY BOTTLES (@750ML)		70		140
DIMENSIONS - W X D X H (BC95W) MM		645 W x 635 D x 1770 H		
DIMENSIONS - W X D X H (BC200W) MM		1290 W x 635 D x 1770 H		
WEIGHT UNPACKED (KG)		150		220
DOOR TYPE		Standard: GD (Glass Door)		
FINISH (INTERIOR AND EXTERIOR EXCLUDING REAR AND UNDER)		Black exterior, Stainless Steel interior		
SHELVES/DOOR		NIL		NIL
ELECTRICAL				
POWER SUPPLY		10 amp		10 amp
RUNNING AMPS		1.8		2.0
GAS TYPE				
REFRIGERANT		R134a		R134a

Prices do not include GST. Prices and specifications are subject to change without notice.

Options

General **counters + back bars**

Glass Chiller
Glass Chiller remote
Glass Chiller slimline remote

Boronia
Boronia remote
Cameo
Cameo remote



Choice of finishes



LED lighting to solid doors



Right hand services



Triple glazed heated glass doors



Cylindrical locks



Pass-through



Locking tabs



Stainless steel shelves

OPTIONS	BORONIA				CAMEO					GLASS CHILLER	
	B1	B2	B3	B4	C1	C2	C3	C4	C5R	GC1	GC2
	1 DOOR	2 DOOR	3 DOOR	4 DOOR	1 DOOR	2 DOOR	3 DOOR	4 DOOR	5 DOOR*	1 DOOR	2 DOOR
Black rear	\$185	\$370	\$555	\$740	\$185	\$370	\$555	\$740	\$925	\$185	\$370
430 grade stainless steel rear & under	\$185	\$370	\$555	\$740	\$185	\$370	\$555	\$740	\$925	\$185	\$370
4622 stainless steel interior & exterior excluding rear and under	\$385	\$770	\$1,155	\$1,540	\$385	\$770	\$1,155	\$1,540	\$1,925	\$385	\$770
4622 stainless steel rear & under	\$285	\$570	\$855	\$1,140	\$285	\$570	\$855	\$1,140	\$1,425	\$285	\$570
Colour finish other than black and white	POA	POA	POA	POA	POA	POA	POA	POA	POA	POA	POA
Black countertop on black cabinet	\$150	\$300	\$450	\$600	\$150	\$300	\$450	\$600	\$750	N/A	N/A
Powdercoat exterior only black and white excluding rear and under	\$1,085	\$1,540	\$1,995	\$2,450	\$1,085	\$1,540	\$1,995	\$2,450	\$2,905	N/A	N/A
Cylindrical locks	\$135	\$270	\$405	\$540	\$135	\$270	\$405	\$540	\$675	N/A	N/A
Locking tabs	\$30	\$60	\$90	\$120	\$30	\$60	\$90	\$120	\$150	N/A	N/A
Warm LED lights	\$200	\$400	\$600	\$800	\$200	\$400	\$600	\$800	\$1,000	N/A	N/A
Dimmable LED Lights	\$750	\$750	\$750	\$750	\$750	\$750	\$750	\$750	\$750	N/A	N/A
Light to solid doors	\$155	\$155	\$310	\$465	\$155	\$155	\$310	\$465	\$620	N/A	N/A
Extra plastic coated shelf with clips	\$57	\$114	\$171	\$228	\$57	\$114	\$171	\$228	\$285	\$57	\$114
Stainless steel shelf upgrade (each)	\$195	\$390	\$585	\$780	\$195	\$390	\$585	\$780	\$975	\$195	\$390
Adjustable legs (150 mm high, included on remotes)	\$60	\$60	\$60	\$90	\$60	\$60	\$60	\$90	\$90	\$60	\$60
DOOR OPTIONS											
Triple glazed heated glass doors	\$595	\$1,190	\$1,785	\$2,380	\$595	\$1,190	\$1,785	\$2,380	\$2,975	N/A	N/A
PASS-THROUGH (refrigerator only)											
Solid doors	\$845	\$1,690	\$2,535	\$3,380	\$845	\$1,690	\$2,535	\$3,380	\$4,120	N/A	N/A
Triple glazed glass doors	\$1,360	\$2,300	\$3,240	\$4,190	\$1,360	\$2,300	\$3,240	\$4,190	\$5,050	N/A	N/A
Heated triple glazed glass doors	\$1,870	\$2,740	\$4,110	\$5,480	\$1,870	\$2,740	\$4,110	\$5,480	\$6,850	N/A	N/A
RH services (services to right hand side)	\$215										
Solenoid fitted (remote only)	\$295										
Hand valves fitted (remote only)	\$250										
NOTES											

- Total height includes legs—remote
- Total height includes castors—self contained
- Optional adjustable legs (supplied loose) in lieu of castors adds 30 mm to overall height
- Heated and pass-through doors may lower ambient rating
- Pass-through model will increase depth of cabinet by 70 mm
- Light with on/off switch is standard on glass door cabinets only (excludes solid door and GC models)
- *5 Door Cameo star options are for remote only
- Some Cameo models available in freezers POA



Topaz café range

Topaz Top Mount

self contained



Digital controller



Door cut out switch



Cylindrical locks



Internal LED lights



10 Amp power

Topaz Top Mount upright, one or two door fridges and freezers are perfectly suited to the fast-growing café market for those with a tighter budget. These units feature a stainless steel finish, internal lighting, adjustable shelving and are perfect for storage.



Advantages

- Fridge designed for 38°C ambient operating environment
- Freezer designed for 36°C ambient operating environment
- Adjustable electronic controller with digital temperature display
- Internal light
- Top mounted self-contained cabinet
- Auto defrost utilising waste heat recovery vaporiser
- Optimised ducted air flow system
- Large storage capacity
- Four adjustable plastic coated shelves/door
- Self-closing solid doors
- Peace of mind auto defrost
- Cylindrical locks
- Shelves can accommodate 2/1 Gastronorm pans

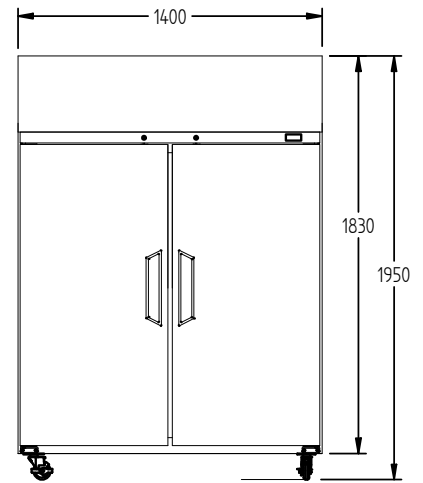
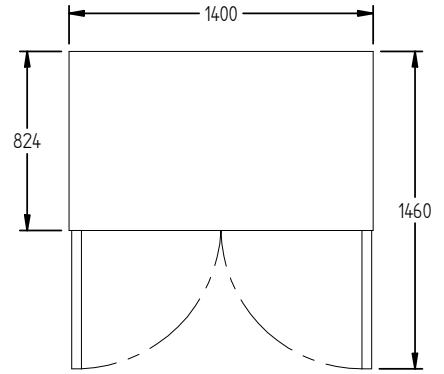
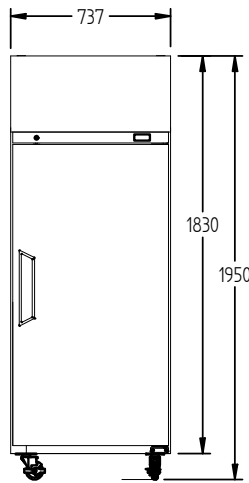
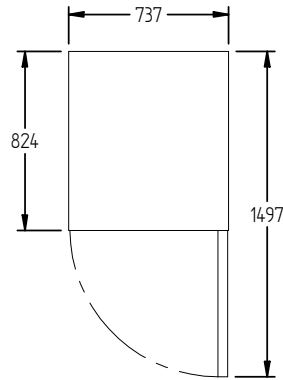
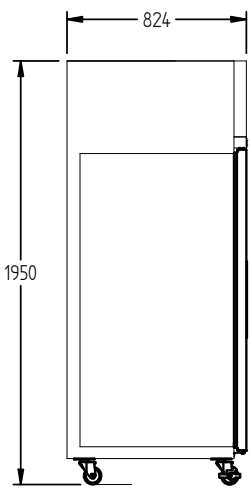

MODEL		1 DOOR	2 DOOR
H (REFRIGERATOR +1°/+4°C)	Stainless Steel, Solid door	HTG1SS \$3,902	HTG2SS \$5,230
L (FREEZER -18°/-22°C)	Stainless Steel, Solid door	LTG1SS \$4,311	LTG2SS \$5,812

SPECIFICATIONS

CAPACITY	580 litres	1080 litres
DIMENSIONS - W X D X H MM	737 W x 824 D x 1950 H	1400 W x 824 D x 1950 H
WEIGHT UNPACKED (KG)	170	220

STANDARD INCLUSIONS

DOOR TYPE	Standard: S (Solid door)	
FINISH	S (Stainless steel) interior and exterior excluding rear and under	
SHELVES	4	8

ELECTRICAL

POWER SUPPLY	10amp	10amp
FRIDGE MODELS	RUNNING AMPS 2.6	3.3
FREEZER MODELS	RUNNING AMPS 3.3	4.9

GAS TYPE

REFRIGERANT	FRIDGE MODELS R134a	R134a
	FREEZER MODELS R404a	R404a

Topaz Under Counter

self contained



Digital controller

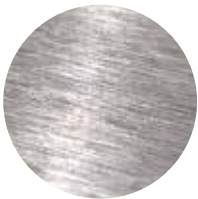

Stainless steel finish



Easy access cleaning

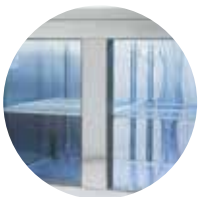

LED lighting



10 Amp power

Topaz two and three door quality stainless steel under counter fridges and freezers are perfectly suited to the fast growing café market for the budget conscious. These units feature energy efficient and long life LED lighting and adjustable shelving.



Advantages

- Fridges are designed for 38°C ambient operating environment
- Freezers are designed for 36°C ambient operating environment
- Adjustable electronic controller with digital temperature display
- High efficiency, long life LED strip lighting
- Digital controller for temperature accuracy
- Forced air refrigeration system
- Auto defrost utilising waste heat recovery vaporiser
- Large storage capacity
- One adjustable plastic coated shelf per door
- Self closing solid doors
- Face mounted hinges (ready for installation on plinths)

**TU2SDSS/TU3DSS
MODEL
SIDE VIEW**

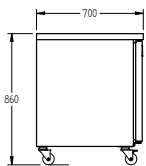

**TU2SDSS-12
MODEL
SIDE VIEW**

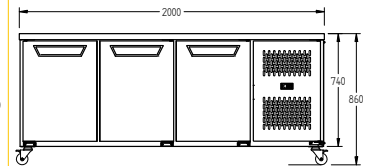
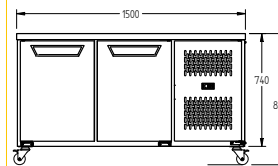
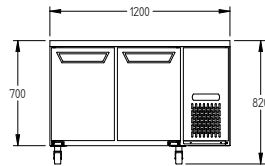
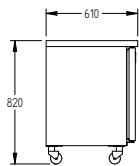

MODEL		2 DOOR		2 DOOR		3 DOOR	
H (REFRIGERATOR +1°/+4°C)	STAINLESS STEEL, SOLID DOOR	HTU2SDSS-12	\$3,031	HTU2SDSS	\$3,568	HTU3DSS	\$4,039
L (FREEZER -18°/-22°C)	STAINLESS STEEL, SOLID DOOR			LTU2SDSS	\$4,318	LTU3DSS	\$4,598

SPECIFICATIONS

CAPACITY LITRES	210	320	475
DIMENSIONS - W X D X H MM (ON CASTORS)	1200 W x 610 D x 800 H	1500 W x 700 D x 860 H	2000 W x 700 D x 860 H
WEIGHT UNPACKED (KG)	120	140	170
DOOR TYPE	Standard: SD (Solid Door)		
FINISH (INTERIOR AND EXTERIOR EXCLUDING REAR AND UNDER)	SS (Stainless Steel)		
SHELVES/DOOR	2	1	1

ELECTRICAL

POWER SUPPLY	10 amp	10 amp	10 amp
FRIDGE MODELS	RUNNING AMPS	2.5	2.5
FREEZER MODELS	RUNNING AMPS	4.0	4.0

GAS TYPE

REFRIGERANT	FRIDGE MODELS	134a	134a	134a
REFRIGERANT	FREEZER MODELS		404a	404a

Topaz Cake & Food display

self contained



Digital controller



Adjustable shelves



Double glazed,
heated glass



Hairline edge 45° cut glass



10 Amp power

Topaz Cake And Food display cabinets are perfectly suited to the fast-growing café market and for those with a tighter budget.

Cabinets are available in four widths from 900 mm to 1800 mm in two different heights. The standard height of the units is 1200 mm with two adjustable shelves and base, while the high units are 1380 mm with three adjustable shelves and base.

These units feature heated glass on the front, top and sides to minimise condensation and the adjustable shelves feature energy efficient and long life LED lighting.



Advantages

- Designed for 32°C/65% ambient operating environment
- Adjustable electronic controller with two digital temperature displays
- High efficiency, long life LED strip lighting under each shelf and glass top
- Ventilation at rear of cabinet
- Auto defrost utilising waste heat recovery vaporiser
- Easy to clean condenser with a removable rear vent
- Double glazed heated glass panels on front, top and both sides
- Two adjustable shelves (flat and angle positions) plus base for the HTCF models (three for HTCHF models)
- One piece metal shelves for added strength (2 pieces/level for 1800 mm displays)
- Sliding Argon E rear sliding doors
- Packed for shipping in a crate (forklift required)
- Supplied on castors

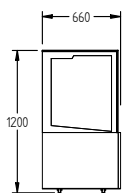

HTCF

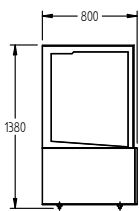

HTCFH

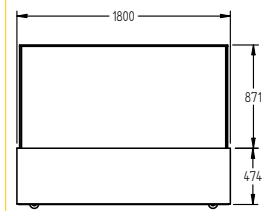
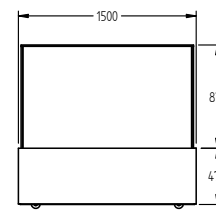
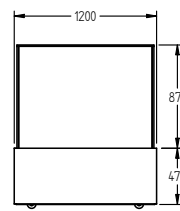
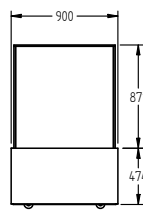
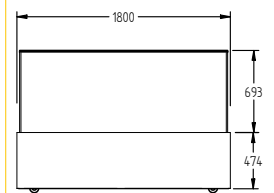
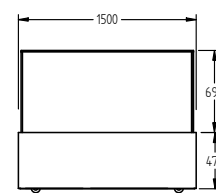
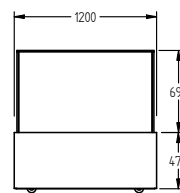
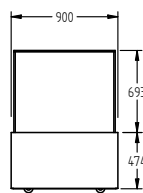

MODEL		900 MM		1200 MM		1500 MM		1800 MM	
HTCF (REFRIGERATOR +1°/+4°C)	Standard version	HTCF9	\$4,244	HTCF12	\$4,843	HTCF15	\$5,766	HTCF18	\$6,411
HTCFH (REFRIGERATOR +1°/+4°C)	High version	HTCFH9	\$5,166	HTCFH12	\$5,904	HTCFH15	\$6,827	HTCFH18	\$7,841

SPECIFICATIONS

DIMENSIONS - W X D X H (HTCF) (ON CASTORS) MM	900 W x 660 D x 1200 H	1200 W x 660 D x 1200 H	1500 W x 660 D x 1200 H	1800 W x 660 D x 1200 H
DIMENSIONS - W X D X H (HTCFH) (ON CASTORS) MM	900 W x 800 D x 1380 H	1200 W x 800 D x 1380 H	1500 W x 800 D x 1380 H	1800 W x 800 D x 1380 H
WEIGHT UNPACKED (KG)	220	250	300	320
DOOR TYPE	Standard: SL (Sliding rear doors)			
FINISH	SS (Stainless Steel exterior)			
SHELVES (INCLUDING BASE) HTCF VERSION	3	3	3	3
SHELVES (INCLUDING BASE) HTCFH VERSION	4	4	4	4

ELECTRICAL

POWER SUPPLY	10 amp	10 amp	10 amp	10 amp
RUNNING AMPS	3.0	3.4	3.8	4.6
RUNNING AMPS	4.5	5.0	7.0	7.5

GAS TYPE

REFRIGERANT - HTCF VERSION	R134a	R134a	R134a	R134a
REFRIGERANT - HTCFH VERSION	R134a	R404a	R404a	R404a

Prices do not include GST. Prices and specifications are subject to change without notice.

Topaz Milk

self contained



Digital controller



Cylindrical locks



Adjustable plastic coated shelves



LED lighting



10 Amp power

Topaz Milk single door fridge is an ideal under counter storage fridge for high use areas. The units are available in white or stainless finish with your choice of a glass or stainless steel solid door. These units perfectly suited to the fast-growing café market or for the budget conscious. The cabinets feature energy efficient and long life LED lighting and adjustable shelving.



Advantages

- Designed for 32°C ambient operating environment
- Adjustable electronic controller with digital display
- High efficiency, long life LED strip lighting
- Self-contained cabinet
- Auto defrost utilising waste heat recovery vaporiser
- On/off switch for interior light
- Forced fan evaporator air flow
- Large storage capacity
- Self closing triple glazed doors for higher efficiency and reduced condensation
- Cylindrical locks
- 2 x Adjustable shelves
- Fitted with rollers at the rear, rubber feet at the front
- Holds up to 30 x 2 Litre containers

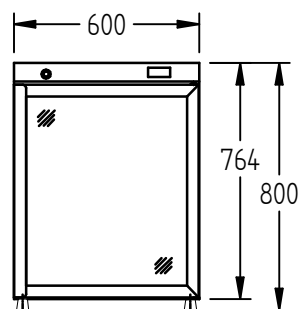
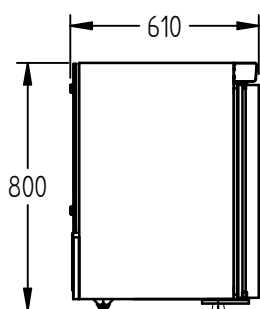

GLASS DOOR

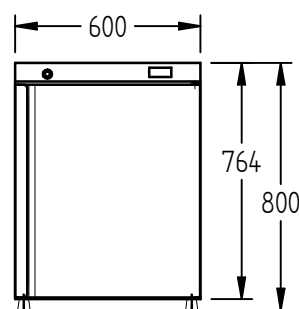

SOLID DOOR

MODEL		HTM145	
H (REFRIGERATOR +1°/+4°C)	White, Glass Door	HTM145GDCB	\$1,691
H (REFRIGERATOR +1°/+4°C)	Stainless Steel, Solid Door	HTM145SDSS	\$1,896
SPECIFICATIONS			
CAPACITY LITRES	145		
DIMENSIONS - W X D X H MM	600 W x 610 D x 800 H		
WEIGHT UNPACKED (KG)	55		
DOOR TYPE	Standard: GD (Glass Door) SD (Solid Door)		
FINISH (INTERIOR AND EXTERIOR EXCLUDING REAR AND UNDER)	CB (White) SS (Stainless Steel)		
SHELVES	2		
ELECTRICAL			
POWER SUPPLY	10 amp		
RUNNING AMPS	1.0		
GAS TYPE			
REFRIGERANT	R134a		

Prices do not include GST. Prices and specifications are subject to change without notice.

Topaz Bottle Cooler

self contained



Digital controller



Cylindrical locks



Adjustable plastic coated shelves



LED lighting



10 Amp power

The Topaz Bottle Cooler models are available as a two, three or four door units with a black interior and exterior finish. Holding temperature range is 4°C to 10°C. The units are self-contained and are suited to the fast growing café market for those with a budget in mind.



Advantages

- Designed for 38°C ambient operating environment
- Forced air refrigeration system
- Adjustable electronic controller with digital temperature display
- Two adjustable shelves (one piece) per door
- Double glazed glass doors
- On levelling feet – roller castor to rear (HTB models)
- On feet (HTD model) for shelf or bench mounting
- On/off switch for interior LED lights
- HTD model is capable of having two temperature zones (dual controller)
- Low maintenance static condenser for HTB models
- Front breathing condenser HTD model

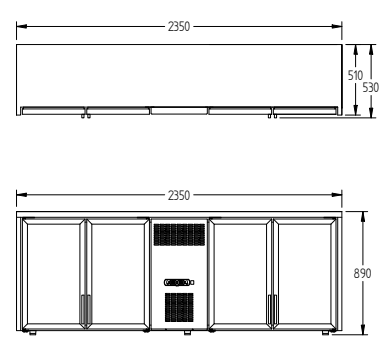
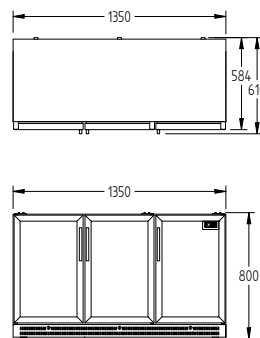
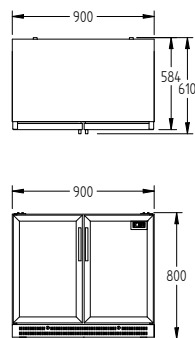
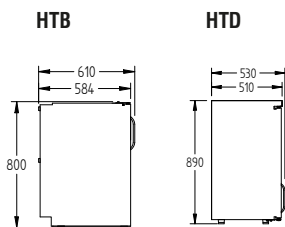

MODEL		2 DOOR		3 DOOR		4 DOOR	
H (REFRIGERATOR +4°/+10°C)	Black	HTB2GB	\$3,798	HTB3GB	\$4,508	HTD4GB	\$6,129
SPECIFICATIONS							
CAPACITY LITRES		150		240		475	
DIMENSIONS - W X D X H (BC) MM		900 W x 584 D x 800 H		1350 W x 584 D x 800 H		2350 W x 510 D x 890 H	
WEIGHT UNPACKED (KG)		85		118		170	
DOOR TYPE		Standard: G (Glass Door)					
FINISH (INTERIOR AND EXTERIOR EXCLUDING REAR AND UNDER)		B (Black)					
SHELVES/DOOR		2		2		2	
ELECTRICAL							
POWER SUPPLY		10 amp		10 amp		10 amp	
RUNNING AMPS		2.7		3.1		3.8	
GAS TYPE							
REFRIGERANT		R134a		R134a		R134a	

Prices do not include GST. Prices and specifications are subject to change without notice.





Blast chiller freezers

Blast Chiller reach in

self contained



Electronic control panel



Simple to operate



Gastronorm pan compatible



Food probe

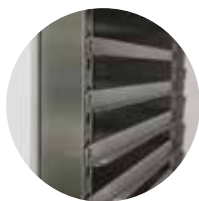

75 mm slide clearance

Designed to give caterers complete control of the chilling/freezing process, and to eliminate the hazards of slow-cooling. Our blast chiller/freezers deliver performance that exceeds food safety legislation standards.

Our chillers are HACCP compliant and meet guidelines for cook chill catering systems worldwide.



Advantages

- Easy to use unique Williams Easy Blast 1-2-3 state of the art control panel—three simple steps to initiate blast cycles
- Choice of hard, soft, store and core food temperature probe controlled cycles with audible alarm indicating end of cycle
- Designed for 43°C ambient environment
- Fitted with slides to suit 1 x 1 Gastronorm containers and shelves (not supplied)
- Self closing door to minimises temperature gain, reducing energy consumption
- Foodsafe stainless steel exterior and interior
- 75mm space between slides
- Coved internal liner
- One core food temperature probe for accurate measurement and control
- Large, energy efficient, high velocity fans and large surface area evaporator—easy access
- Advanced airflow design enabling uniform freezing across the product for consistent product quality
- Automatically switches to storage mode at the end of each cycle

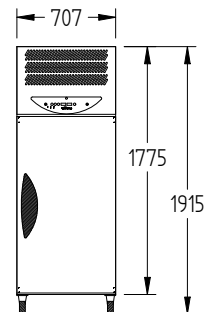
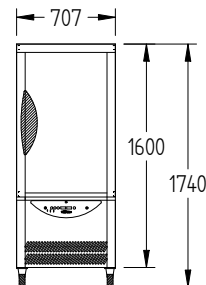
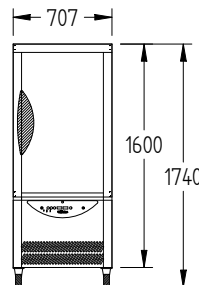
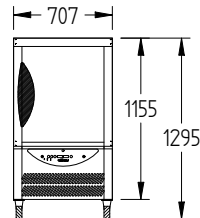
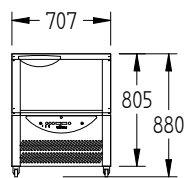
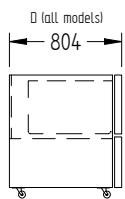

MODEL		10 KG		20 KG		30 KG		40 KG		50 KG	
Blast Chiller Freezer	Self contained	WBCF10	\$11,788	WBCF20	\$14,248	WBCF30	\$18,963	WBCF40	\$19,475	WBCF50	\$22,140

SPECIFICATIONS

CAPACITY - CHILLING/FREEZING PER 90/240 MIN CYCLE #	10 kg	20 kg	30 kg	40 kg	50 kg
CAPACITY - 1/1 GN PANS	3	6	10	10	13
DIMENSIONS - W X D X H (ON CASTORS) MM	707 W x 804 D x 880 H	707 W x 804 D x 1295 H	707 W x 804 D x 1740 H	707 W x 804 D x 1740 H	707 W x 804 D x 1915 H
WEIGHT UNPACKED (KG)	50	140	190	190	205
DOOR TYPE	Standard: SD (Solid Door)				
FINISH (INTERIOR AND EXTERIOR EXCLUDING REAR AND UNDER)	SS (Stainless Steel)				
SHELF SLIDES TO SUIT 1/1 GN PANS AND SHELVES	3	6	10	10	13

ELECTRICAL

POWER SUPPLY	10 amp	10 amp	15 amp	15 amp	3 Phase	
FRIDGE MODELS	RUNNING AMPS	4.0	6.0	9.9	9.9	5.8

GAS TYPE

REFRIGERANT	R404a	R404a	R404a	R404a	R404a
--------------------	-------	-------	-------	-------	-------

Based on Blast chilling of 50 mm max depth of uncovered dense food such as mashed potato. Times will vary depending on the container and food types as well as the thermal conductivity of the food.

*** For **Blast chiller OPTIONS** see page 107

Prices do not include GST. Prices and specifications are subject to change without notice.

Blast Chiller roll in

700mm remote



Thermal printer for HACCP compliance



Electronic control panel



90 kg – 1000 kg load capacities



Food probe



Gastronorm trolley compatible

Designed to give caterers complete control of the chilling and freezing processes, and to eliminate the hazards of slow-cooling. Our modular blast chillers and freezers deliver performance that exceeds food safety legislation standards.

They are HACCP compliant and meet guidelines for cook chill catering systems worldwide.

The AirSmart (advanced special air flow) design developed by Williams delivers even product chilling that eliminates product dehydration and ensures food is maintained in the best possible condition.



Advantages

- Easy to use, unique Williams Easy Blast 1-2-3 state of the art control panel—three simple steps to initiate blast cycles
- Three core food temperature probes for accurate measurement and control
- Automatic defrost at the end of every blast cycle or every six hours ensuring efficient and effective performance
- Automatic switching to storage mode at the end of each cycle offering additional storage capacity
- High quality thermal printer for blast cycle data storage and printout for full HACCP compliance
- Large, energy efficient, high velocity fans and large surface area evaporator—easy access
- Advanced airflow design enabling uniform freezing across the product for consistent product quality
- Designed for fast installation and commissioning, servicing and maintenance with easy to access fans
- Accommodates 1/1 or 2/1 Gn mobile rack to suit any catering requirement
- 700mm clear door opening

Blast chiller freezers

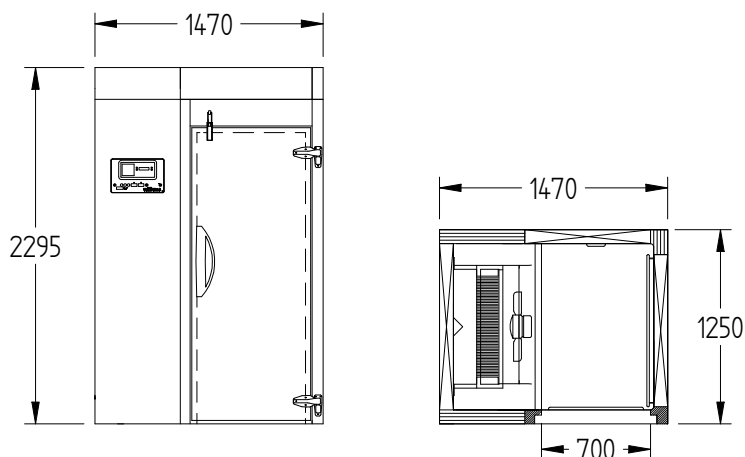

ROLL IN 700 MM REMOTE

MODEL		90 KG		100 KG		120 KG		160 KG		200 KG	
Blast Chiller	Remote	WMBC90	\$42,227	—	N/A	WMBC120	\$42,977	WMBC160	\$43,900	WMBC200	\$44,822
Blast Chiller/ Freezer	Remote	WMBCF90	\$45,853	—	N/A	WMBCF120	\$46,550	WMBCF160	\$47,794	WMBCF200	\$48,672
Blast Freezer	Remote	—	N/A	WMBF100	\$47,255	—	N/A	—	N/A	—	SEE NEXT PAGE

SPECIFICATIONS

CAPACITY - CHILLING/ FREEZING PER 90/240 MIN CYCLE #		90 kg	100 kg	120 kg	160 kg	200 kg
CAPACITY 2/1 TROLLEY	BLAST CHILLER/ FREEZER	1	—	1	1	1
	BLAST FREEZER	—	1	—	—	—
DIMENSIONS W X D X H MM	BLAST CHILLER/ FREEZER	1470 W x 1250 D x 2295 H**	—	1470 W x 1250 D x 2295 H**	1470 W x 1250 D x 2295 H**	1470 W x 1250 D x 2295 H**
	BLAST FREEZER	—	1470 W x 1250 D x 2295 H**	—	—	—
WEIGHT UNPACKED (KG)		650 kg	650 kg	650 kg	650 kg	650 kg
DOOR TYPE				SD (Solid Door)		
FINISH (INTERIOR AND EXTERIOR)				SS (Stainless Steel)		

ELECTRICAL

POWER SUPPLY - 3 PHASE*		16 amp	16 amp	16 amp	16 amp	16 amp
FRIDGE MODELS	BLAST RUNNING AMPS	4.3	5.0	4.3	5.2	5.2

*BLAST CHILLER/FREEZERS ARE RATED FOR 415 V 50 HZ THREE PHASE

GAS TYPE

REFRIGERANT	R404a	R404a	R404a	R404a	R404a
-------------	-------	-------	-------	-------	-------

REFRIGERATION WATTAGES FOR REMOTE UNITS

CHILLER/FREEZER	8.6kW @ -15°C SST	—	10.3kW @ -15°C SST	17.3kW @ -15°C SST	21.0kW @ -15°C SST
FREEZER	—	12.2kW @ -30°C SST	—	—	—

**All Freezer and Chiller/Freezer models are supplied with additional 90 mm floor—adds 90 mm to overall height

Based on Blast chilling of 50 mm max depth of uncovered dense food such as mashed potato. Times will vary depending on the container and food types as well as the thermal conductivity of the food

*** For **Blast chiller OPTIONS** see page 107

Prices do not include GST. Prices and specifications are subject to change without notice.

Blast chiller freezers

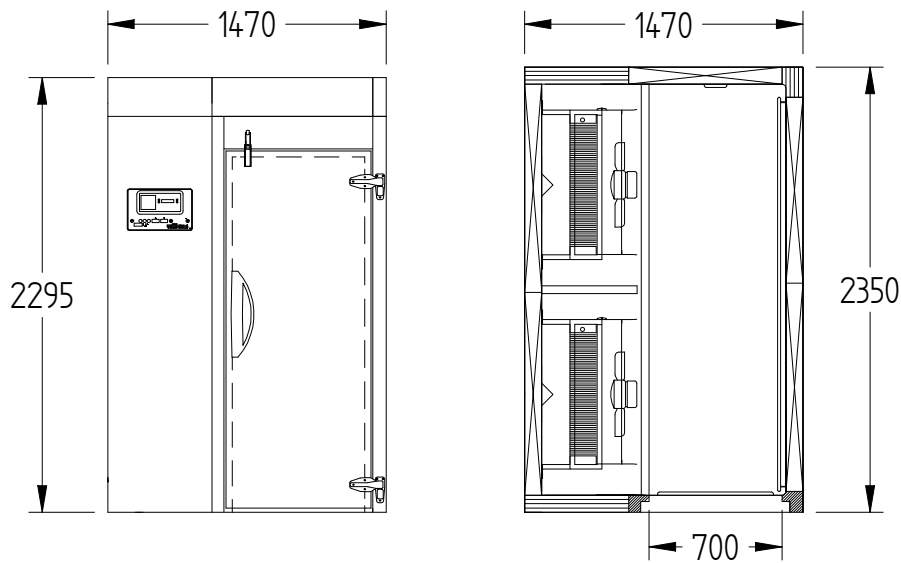

ROLL IN 700 MM REMOTE

MODEL		200 KG		240 KG		320 KG	
Blast Chiller	Remote	—	N/A	WMBC240	\$76,287	WMBC320	\$81,210
Blast Chiller/Freezer	Remote	—	N/A	WMBCF240	\$80,228	WMBCF320	\$86,046
Blast Freezer	Remote	WMBF200	\$82,784	—	N/A	—	N/A

SPECIFICATIONS

CAPACITY - CHILLING/FREEZING PER 90/240 MIN CYCLE #		200 kg	240 kg	320 kg
CAPACITY 2/1 TROLLEY	BLAST CHILLER/FREEZER	—	2	2
	BLAST FREEZER	2	—	—
DIMENSIONS W X D X H MM	BLAST CHILLER/FREEZER	—	1470 W x 2350 D x 2295 H**	1470 W x 2350 D x 2295 H**
	BLAST FREEZER	1470 W x 2350 D x 2295 H**	—	—
WEIGHT UNPACKED (KG)		650 kg	650 kg	650 kg
DOOR TYPE		SD (Solid Door)		
FINISH (INTERIOR AND EXTERIOR)		SS (Stainless Steel)		

ELECTRICAL

POWER SUPPLY - 3 PHASE*		20 amp	20 amp	20 amp
FRIDGE MODELS	BLAST RUNNING AMPS	9	7.7	7.7

*BLAST CHILLER/FREEZERS ARE RATED FOR 415 V 50 HZ THREE PHASE

GAS TYPE

REFRIGERANT	R404a	R404a	R404a
-------------	-------	-------	-------

REFRIGERATION WATTAGES FOR REMOTE UNITS

CHILLER/FREEZER	—	22.5kW @ -15°C SST	25.7kW @ -15°C SST
FREEZER	18.2kW @ -30°C SST	—	—

**All Freezer and Chiller/Freezer models are supplied with additional 90 mm floor—adds 90 mm to overall height

Based on Blast chilling of 50 mm max depth of uncovered dense food such as mashed potato. Times will vary depending on the container and food types as well as the thermal conductivity of the food

Blast Chiller roll in

900mm remote



Thermal printer for HACCP compliance



Electronic control panel



90 kg – 1000 kg load capacities



Food probe



Gastronorm trolley compatible

Designed to give caterers complete control of the chilling and freezing processes, and to eliminate the hazards of slow-cooling. Our modular blast chillers and freezers deliver performance that exceeds food safety legislation standards.

They are HACCP compliant and meet guidelines for cook chill catering systems worldwide.

The AirSmart (advanced special air flow) design developed by Williams delivers even product chilling that eliminates product dehydration and ensures food is maintained in the best possible condition.



Advantages

- Easy to use, unique Williams Easy Blast 1-2-3 state of the art control panel—three simple steps to initiate blast cycles
- Three core food temperature probes for accurate measurement and control
- Automatic defrost at the end of every blast cycle or every six hours ensuring efficient and effective performance
- Automatic switching to storage mode at the end of each cycle offering additional storage capacity
- High quality thermal printer for blast cycle data storage and printout for full HACCP compliance
- Large, energy efficient, high velocity fans and large surface area evaporator—easy access
- Advanced airflow design enabling uniform freezing across the product for consistent product quality
- Designed for fast installation and commissioning, servicing and maintenance with easy to access fans
- Accommodates 1/1 or 2/1 Gn mobile rack to suit any catering requirement
- 900 mm door opening

Blast chiller freezers

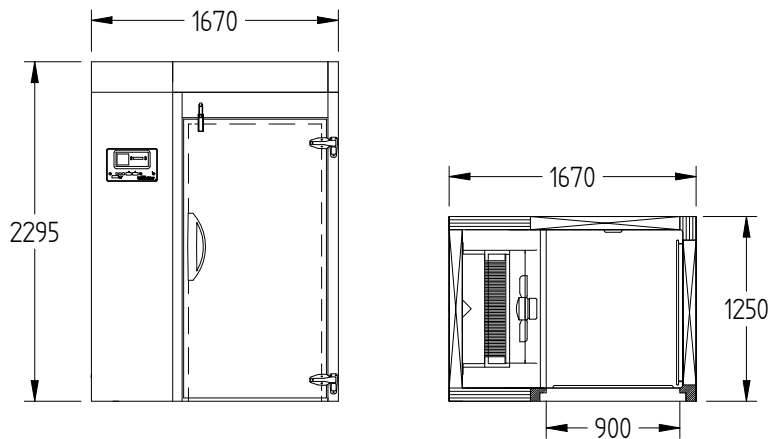

ROLL IN 900 MM REMOTE

MODEL		90 KG		100 KG		120 KG		160 KG		200 KG	
Blast Chiller	Remote	WMBC90C	\$45,552	—	N/A	WMBC120C	\$46,381	WMBC160C	\$47,258	WMBC200C	\$48,078
Blast Chiller/ Freezer	Remote	WMBCF90C	\$49,070	—	N/A	WMBCF120C	\$49,963	WMBCF160C	\$51,152	WMBCF200C	\$51,924
Blast Freezer	Remote	—	N/A	WMBF100C	\$50,672	—	N/A	—	N/A	—	SEE NEXT PAGE

SPECIFICATIONS

CAPACITY - CHILLING/ FREEZING PER 90/240 MIN CYCLE #		90 kg	100 kg	120 kg	160 kg	200 kg
CAPACITY 2/1 COMBI TROLLEY	BLAST CHILLER/ FREEZER	1	—	1	1	1
	BLAST FREEZER	—	1	—	—	—
DIMENSIONS BLAST FREEZER W X D X H	BLAST CHILLER/ FREEZER	1670 W x 1250 D x 2295 H**	—	1670 W x 1250 D x 2295 H**	1670 W x 1250 D x 2295 H**	1670 W x 1250 D x 2295 H**
	BLAST FREEZER	—	1670 W x 1250 D x 2295 H**	—	—	—
WEIGHT UNPACKED (KG)		650 kg	650 kg	650 kg	650 kg	650 kg
DOOR TYPE		SD (Solid Door)				
FINISH (INTERIOR AND EXTERIOR)		SS (Stainless Steel)				

ELECTRICAL

POWER SUPPLY - 3 PHASE*		16 amp	16 amp	16 amp	16 amp	16 amp
FRIDGE MODELS	BLAST RUNNING AMPS	4.3	5.0	4.3	5.2	5.2

*BLAST CHILLER/FREEZERS ARE RATED FOR 415 V 50 HZ THREE PHASE

GAS TYPE

REFRIGERANT	R404a	R404a	R404a	R404a	R404a
-------------	-------	-------	-------	-------	-------

REFRIGERATION WATTAGES FOR REMOTE UNITS

CHILLER/FREEZER	8.6kW @ -15°C SST	—	10.3kW @ -15°C SST	17.3kW @ -15°C SST	21.0kW @ -15°C SST
FREEZER	—	12.2kW @ -30°C SST	—	—	—

**All Freezer and Chiller/Freezer models are supplied with additional 90mm floor—adds 90 mm to overall height.

Based on Blast chilling of 50 mm max depth of uncovered dense food such as mashed potato. Times will vary depending on the container and food types as well as the thermal conductivity of the food.

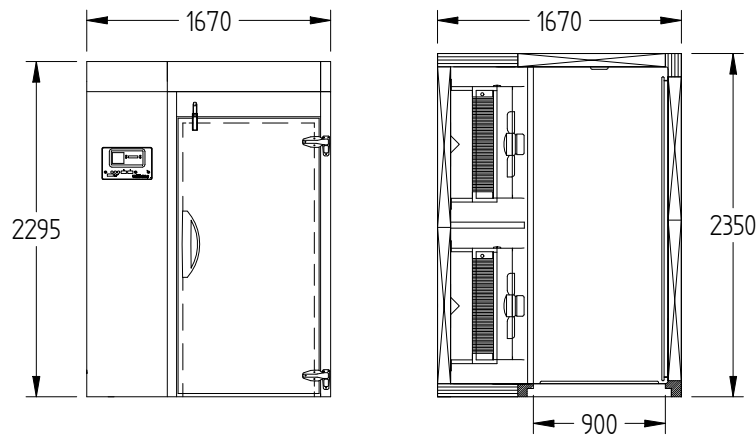

ROLL IN 900 MM REMOTE

MODEL		200 KG	240 KG	320 KG
Blast Chiller	Remote	—	WMBC240C \$80,902	WMBC320C \$85,875
Blast Chiller/Freezer	Remote	—	WMBCF240C \$83,924	WMBCF320C \$89,833
Blast Freezer	Remote	WMBF200C \$86,686	—	N/A

SPECIFICATIONS

CAPACITY - CHILLING/FREEZING PER 90/240 MIN CYCLE #		200 kg	240 kg	320 kg
CAPACITY 2/1 COMBI TROLLEY	BLAST CHILLER/FREEZER	—	2	2
	BLAST FREEZER	2	—	—
DIMENSIONS BLAST FREEZER W X D X H	BLAST CHILLER/FREEZER	—	1670 W x 2350 D x 2295 H**	1670 W x 2350 D x 2295 H**
	BLAST FREEZER	1670 W x 2350 D x 2295 H**	—	—
WEIGHT UNPACKED (KG)		650 kg	650 kg	650 kg
DOOR TYPE		SD (Solid Door)		
FINISH (INTERIOR AND EXTERIOR)		SS (Stainless Steel)		

ELECTRICAL

POWER SUPPLY - 3 PHASE*		20 amp	20 amp	20 amp
FRIDGE MODELS	BLAST RUNNING AMPS	9	7.7	7.7

*BLAST CHILLER/FREEZERS ARE RATED FOR 415 V 50 HZ THREE PHASE

GAS TYPE

REFRIGERANT	R404a	R404a	R404a
-------------	-------	-------	-------

REFRIGERATION WATTAGES FOR REMOTE UNITS

CHILLER/FREEZER	—	22.5kW @ -15°C SST	25.7kW @ -15°C SST
FREEZER	18.2kW @ -30°C SST	—	—

** All Freezer and Chiller/Freezer models are supplied with additional 90mm floor—adds 90 mm to overall height.

Based on Blast chilling of 50 mm max depth of uncovered dense food such as mashed potato. Times will vary depending on the container and food types as well as the thermal conductivity of the food.

*** For **Blast chiller OPTIONS** see page 107

Prices do not include GST. Prices and specifications are subject to change without notice.

Options

Blast chiller freezers

Blast Chiller, reach in
Blast Chiller, roll in—700 mm
Blast Chiller, roll in—900 mm



Stainless steel rear and under



Extra slides for shelfpan



Plastic coated shelves



Stainless steel shelves

OPTIONS	REACH IN					ROLL IN CHILLER/FREEZER						ROLL IN FREEZER	
	10	20	30	40	50	90	120	160	200	240	320	100	200
Stainless steel rear & under			\$370									N/A	N/A
Plastic coated shelf (each)			\$107									N/A	N/A
Stainless steel shelf (each)			\$240									N/A	N/A
Extra pair of slides for shelf pan (each)			\$55									N/A	N/A
Pass thru			N/A						\$2,000			\$2,000	\$2,000
External ramp			N/A						\$2,000			\$2,000	\$2,000
Storage Pod *													
Chiller			N/A					\$5,800			\$6,800		N/A
Chiller/Freezer			N/A					\$6,800			\$7,800		N/A
Freezer			N/A									\$6,800	\$7,800

NOTES (Reach In):

- Height includes castors
- Optional adjustable legs (supplied loose) in lieu of castors adds 30 mm to overall height
- WBCF50 model requires tundish for drainage
- Based on blast chilling of 50 mm max depth of uncovered dense food such as mash potato
- Times will vary depending on the container and food types as well as the thermal conductivity of the food

NOTES (Roll In):

- # All freezer and chiller/freezer models supplied with additional 90 mm floor—adds 90 mm to overall height
- A 90 mm insulated and heated floor requires maximum 100 mm recess or optional external ramp
- All models are constructed from modular panels delivered flat packed for erection and installation on site by others
- All roll in blast chiller/freezers and blast freezers require 3 phase 415 volt power at the control panel
- The evaporator section is supplied in one piece. Safe handling should be considered when planning installation
- All of the above prices exclude main condensing unit and storage pod refrigeration system
- * Storage pod adds 200 mm to height of cabinet
- Based on blast chilling of 50 mm max depth of uncovered dense food such as mash potato
- Times will vary depending on the container and food types as well as the thermal conductivity of the food
- Recommendation for sizing of condensing unit and advice on electrical requirements available on request

A photograph of a commercial kitchen with stainless steel equipment, including a range hood, a cooktop with burners, and a large oven with multiple drawers. The image is dark and has a green overlay on the right side.

Foodservice **specialised**

Mobile Banquet Cart

self contained



Electronic controller



Full bumpers for protection



Self closing door



Heavy duty,
lockable castors



10 Amp power

One door
2/1 Gastronorm
cabinets—refrigerated
and heated, for
transporting chilled
or hot food from the
kitchen to banqueting
areas safely.



Advantages

- Designed to keep food above +70°C for up to four hours after switching off (not a regeneration oven) (MHC models)
- Designed to keep food between +1°C to +4°C (MRC model)
- Adjustable electronic controller (with digital temperature display) for greater temperature control
- Fan motors located outside cabinet for longer service and easy maintenance (MHC model)
- Fitted with 2 x 150 mm fans with extended shafts for excellent air circulation (MHC model)
- Fast warm up in +25°C ambient from cold to +82°C in approximately 15 minutes (MHC model)
- Self-closing solid doors
- Swivel and brake castors for easy mobility and stability
- All round bumper for added protection during cabinet movement
- Hermetic Compressor (MRC model only)
- Excellent thermal insulation ensures the heated models, cabinets exterior is safe to touch

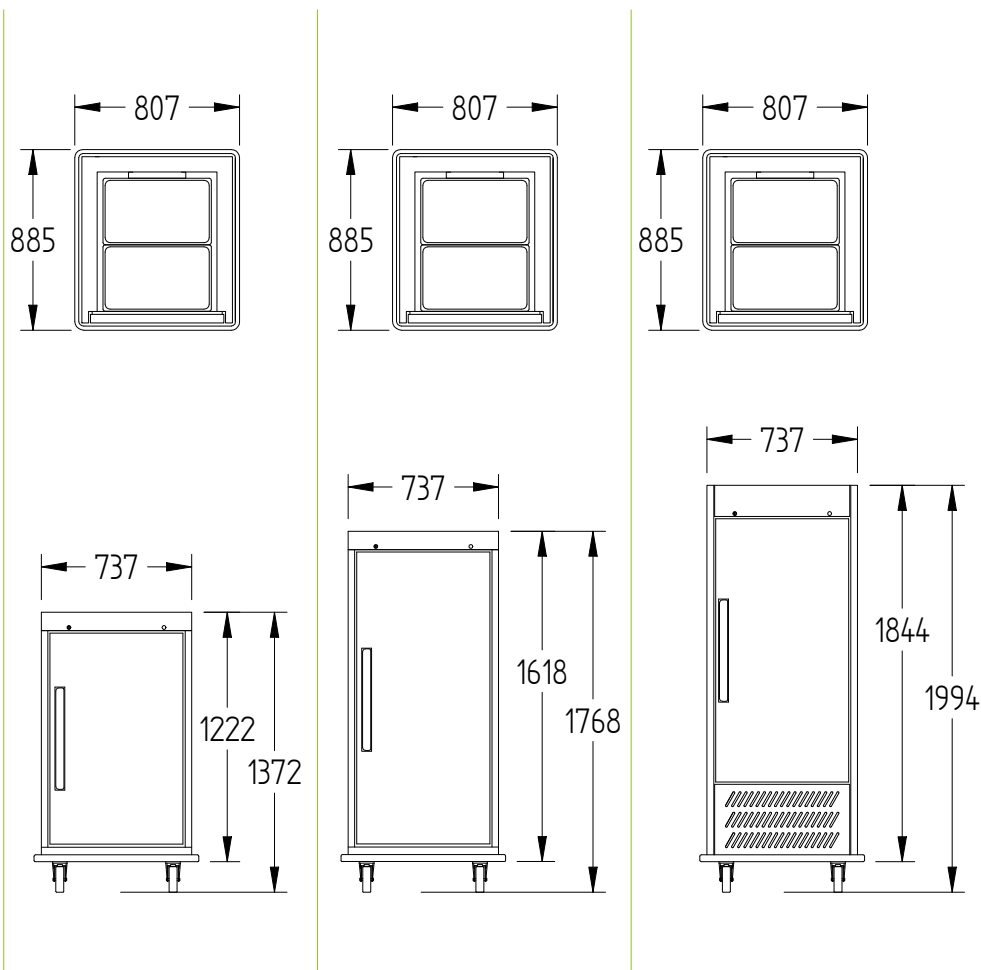

MODEL	MHC10		MHC16-10		MRC16	
MHC (HEATED +78°/+82°C)	MHC10	\$7,704	MHC16-10	\$8,950	—	N/A
MRC (REFRIGERATED +1°/+4°C)	—	N/A	—	N/A	MRC16	\$9,485
SPECIFICATIONS						
CAPACITY - 2/1 50MM DEEP GN PANS	10 tray slides		16 tray slides		16 tray slides	
DIMENSIONS - W X D X H (ON CASTORS) MM	807 W x 885 D x 1372 H		807 W x 885 D x 1768 H		807 W x 885 D x 1994 H	
WEIGHT UNPACKED (KG)	110		150		140	
STANDARD INCLUSIONS ***						
DOOR TYPE	Standard: S (Solid Door)					
FINISH (INTERIOR AND EXTERIOR)	S (Stainless Steel)					
TRAY SLIDES	10		16		16	
ELECTRICAL						
POWER SUPPLY	10 amp		10 amp		10 amp	
HEATED MODELS	RUNNING AMPS	5.8	9.0		N/A	
REFRIGERATED MODELS	RUNNING AMPS	N/A	N/A		3.0	
GAS TYPE						
REFRIGERANT	FRIDGE MODELS	N/A	N/A		R134a	

*** For **Mobile banquet cart OPTIONS** see page 123

Prices do not include GST. Prices and specifications are subject to change without notice.

Amber under counter

self contained



Electronic controller



Front breathing



Cylindrical locks



Low noise design



10 Amp power

Compact, robust one door refrigerator and freezer. Ideal for small kitchens and noise sensitive areas.



Advantages

- Solid door models designed for 32°C ambient environment
- Glass door fridge model designed for 25°C ambient environment
- Adjustable electronic controller with digital temperature display
- Two plastic coated shelves
- Front breathing refrigeration system
- Forced draught cooler in refrigerator model
- Low noise design

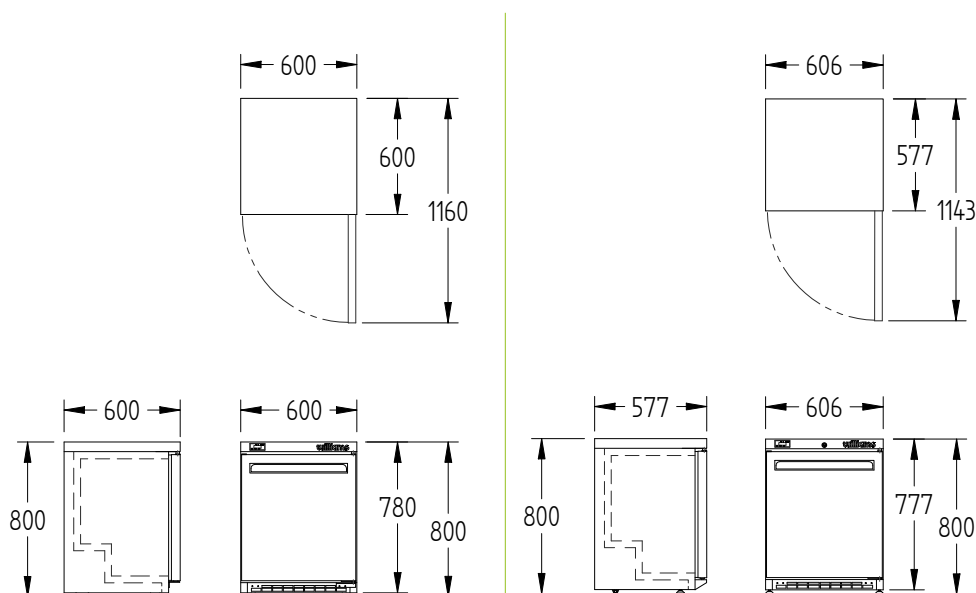

MODEL		HA135		LA135	
H (REFRIGERATOR +1°/+4°C)	SOLID DOOR	HA135LP	\$4,035	—	N/A
H (REFRIGERATOR +1°/+4°C)	GLASS DOOR	HA135LPGD	\$4,173	—	N/A
L (FREEZER -18°/-22°C)	SOLID DOOR	—	N/A	LA135LP	\$4,299

SPECIFICATIONS

CAPACITY LITRES		133		133
DIMENSIONS - W X D X H (ON CASTORS) MM		600 W x 600 D x 800 H		606 W x 577 D x 800 H
WEIGHT UNPACKED (KG)		65		55

STANDARD INCLUSIONS ***

DOOR TYPE		Standard: SD (Solid Door), GD (Glass Door)		
FINISH (INTERIOR AND EXTERIOR EXCLUDING REAR AND UNDER)		SS (Stainless Steel)		
SHELVES		2		2 Fixed

ELECTRICAL

POWER SUPPLY		10 amp		10 amp
FRIDGE MODELS	RUNNING AMPS	1.5		N/A
FREEZER MODELS	RUNNING AMPS	N/A		1.2

GAS TYPE

REFRIGERANT	FRIDGE MODELS	R134a		N/A
	FREEZER MODELS	N/A		R404a

*** For **Amber OPTIONS** see page 123

Prices do not include GST. Prices and specifications are subject to change without notice.

Aztra

self contained



Electronic controller



Compact design



Cylindrical locks



Low noise design



10 Amp power

Compact, robust one door refrigerator and freezer. Available in one door unit as standard, with the option of one or two drawers in lieu of the door. Ideal for small kitchens and noise sensitive areas.



Advantages

- Designed for 32°C ambient environment
- Adjustable electronic controller with digital temperature display
- Two plastic coated shelves
- Front breathing refrigeration system
- Forced draught cooler in both models
- Low noise design
- Optional long life heavy duty drawer systems with one and two drawer modules in both refrigerator and freezer

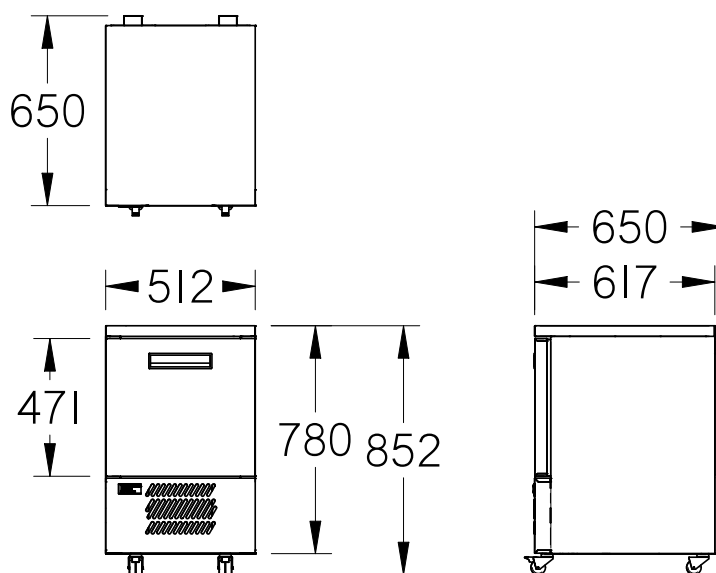

MODEL		AZ1U	
H (REFRIGERATOR +1°/+4°C)	SOLID DOOR	HAZ1U	\$4,136
L (FREEZER -18°/-22°C)	SOLID DOOR	LAZ1U	\$4,406
SPECIFICATIONS			
CAPACITY LITRES		70	
DIMENSIONS - W X D X H (ON CASTORS) MM		512 W x 650 D x 852 H	
WEIGHT UNPACKED (KG)		85	
STANDARD INCLUSIONS ***			
DOOR TYPE		Standard: SD (Solid Door), DR (Drawers Optional)	
FINISH (INTERIOR AND EXTERIOR EXCLUDING REAR AND UNDER)		SS (Stainless Steel)	
SHELVES		2	
ELECTRICAL			
POWER SUPPLY		10 amp	
FRIDGE MODELS	RUNNING AMPS	2.5	
FREEZER MODELS	RUNNING AMPS	3.1	
GAS TYPE			
REFRIGERANT	FRIDGE MODELS	R134a	
	FREEZER MODELS	R404a	

*** For **Aztra OPTIONS** see page 123

Prices do not include GST. Prices and specifications are subject to change without notice.

Jarrah

remote



Electronic controller



Heavy duty drawer runners (optional full drawer shown)



Gastronorm pan compatible



Use under cooking equipment



10 Amp power

Space saving, low height remote refrigerated counter designed specifically to accommodate chargrills and griddles.



Advantages

- Designed for 43°C ambient environment
- Fitted with evaporator, TX valve, controller, fitted plug and condensate drain
- Adjustable electronic controller with digital temperature display
- Forced air refrigeration system
- FC sheet incorporated into top
- JL models - accommodate 2 x 1/1 x 100 mm deep Gn pans (pans included). A 2/1 x 100 mm deep Gn can be used (not supplied)
- JH models - accommodate 1/1 x 150 mm deep Gn pans (pans included)
- Heavy duty drawer runners with reinforced nylon and stainless bushes
- Coved internal floor
- On castors for mobility—legs are supplied with cabinet
- Optional - rear exiting pipes available for JL models (must be notified at time of order)
- JH models can be bottom or rear exiting pipes as standard
- Optional – JH models only available in freezers POA

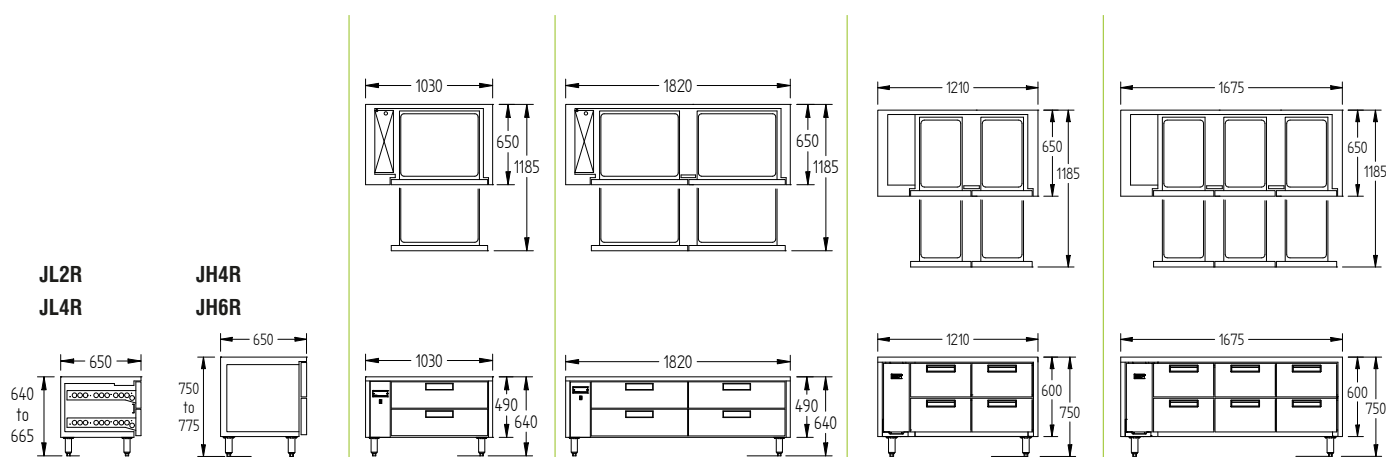

MODEL		JL2R		JL4R		JH4R		JH6R	
H (REFRIGERATOR +1°/+4°C)	REMOTE	JL2R	\$6,237	JL4R	\$8,011	JH4R	\$6,796	JH6R	\$8,722

SPECIFICATIONS

CAPACITY 1/1 GN PAN	4 (100 mm deep)	8 (100 mm deep)	4 (150 mm deep)	6 (150 mm deep)
DIMENSIONS - W X D X H (ON LEGS) MM	1030 W x 650 D x 640 H	1820 W x 650 D x 640 H	1210 W x 650 D x 750 H	1675 W x 650 D x 750 H
WEIGHT UNPACKED (KG)	140	180	150	180

STANDARD INCLUSIONS ***

DRAWERS	2	4	4	6
FINISH (INTERIOR AND EXTERIOR EXCLUDING REAR AND UNDER)	SS (Stainless Steel)			

ELECTRICAL

POWER SUPPLY	10 amp	10 amp	10 amp	10 amp
RUNNING AMPS	0.5	0.7	0.5	0.6

GAS TYPE

REFRIGERANT	R404a	R404a	R404a	R404a
-------------	-------	-------	-------	-------

REFRIGERATION WATTAGES FOR REMOTE UNITS

FRIDGE MODELS	400 @ -5°C SST	650 @ -5°C SST	400 @ -5°C SST	500 @ -5°C SST
---------------	----------------	----------------	----------------	----------------

*** For **Jarrah OPTIONS** see page 123

Prices do not include GST. Prices and specifications are subject to change without notice.

Under Broiler Counter

self contained



Electronic controller



Heavy duty
drawer runners



Gastronorm pan
compatible



Use under cooking
equipment

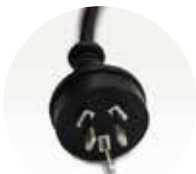

10 Amp power

Space saving, low height refrigerated counter designed specifically to accommodate chargrills and griddles.



Advantages

- Designed for 43°C ambient environment
- Adjustable electronic controller with digital temperature display
- FC sheet incorporated into top
- Forced air refrigeration system
- Auto defrost and waste heat recovery vaporizer
- Accommodates 2 x 1/1 OR 1 x 2/1 x 75 mm deep Gn pans (pans excluded)
- Heavy duty drawer runners with reinforced nylon and stainless bushes
- Coved internal floor
- On castors

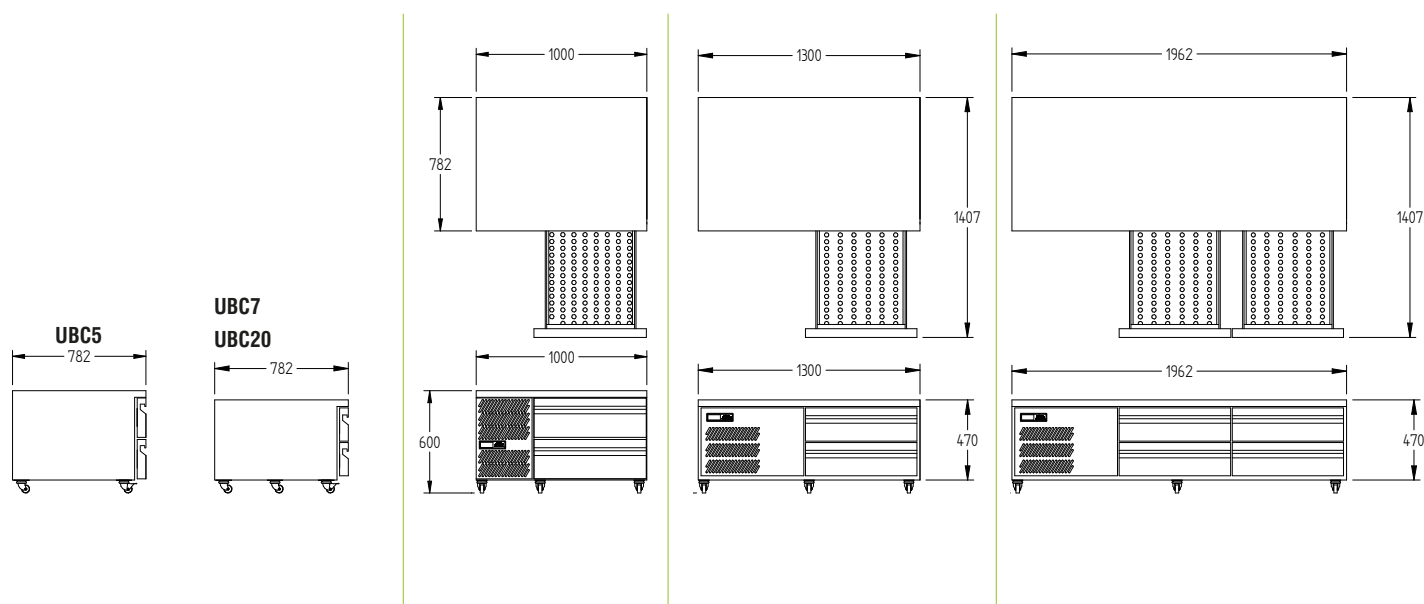

MODEL	UBC5		UBC7		UBC20	
H (REFRIGERATOR SELF CONTAINED +1°/+4°C)	HUBC5	\$7,307	HUBC7	\$7,625	HUBC20	\$8,641
SPECIFICATIONS						
CAPACITY 1/1 GN PAN	4 (150 mm deep)		4 (100 mm deep)		8 (100 mm deep)	
DIMENSIONS - W X D X H (ON CASTORS) MM	1000 W x 782 D x 600 H		1300 W x 782 D x 546 H		1962 W x 782 D x 546 H	
WEIGHT UNPACKED (KG)	130		130		160	
STANDARD INCLUSIONS ***						
DRAWERS	2		2		4	
FINISH (INTERIOR AND EXTERIOR EXCLUDING REAR AND UNDER)	SS (Stainless Steel)					
ELECTRICAL						
POWER SUPPLY	10 amp		10 amp		10 amp	
RUNNING AMPS	1.8		1.8		2.0	
GAS TYPE						
REFRIGERANT	R134a		R134a		R134a	

Prices do not include GST. Prices and specifications are subject to change without notice.

Ruby Roll-in

self contained



Electronic controller



Top mounted
self contained



Gn trolley
compatible



Heavy duty door handle



10 Amp power

The self contained Ruby Roll-in series is a fixed modular cabinet that can be configured for a variety of different uses.

Featuring the latest CoolSmart technology, Ruby refrigerated cabinets can operate efficiently in ambient temperatures of up to 43°C. They are designed to roll in 2/1 Gn trolleys.



Advantages

- Designed for 43°C ambient environment
- Adjustable electronic controller with digital temperature display
- Heavy duty door latch
- Forced air refrigeration system to ensure effective air circulation
- Auto defrost and waste heat recovery vaporizer
- Accommodates 1 x 2/1 Gn size trolley (trolley excluded)
- Top mounted POD refrigeration system for easy installation and servicing
- Cam-locked modular panels ensure each section fits tightly together
- Removable balloon type magnetic door gasket
- Freezer fitted with 90 mm insulated floor
- Optional 90 mm insulated floor available for fridges
- Longer life anti corrosive evaporator coil coating
- A choice of one, two and three door configurations
- Self-closing doors

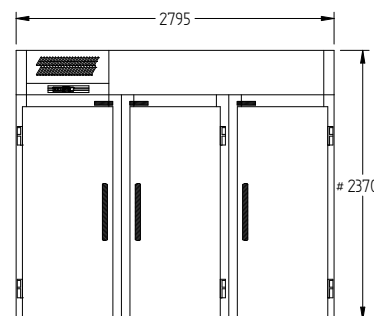
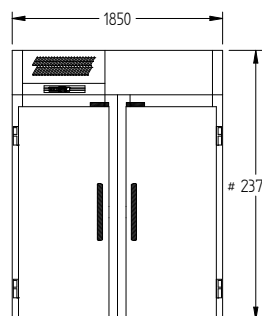
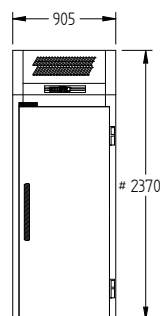
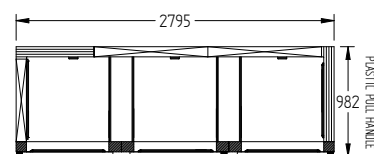
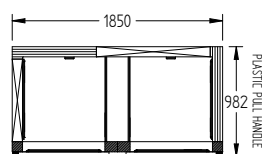
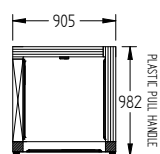

MODEL		1 DOOR	2 DOOR	3 DOOR			
H (REFRIGERATOR +1°/+4°C)	Stainless Steel, Solid Door	HRMR1T	\$13,667	HRMR2T	\$21,386	HRMR3T	\$30,409
L (FREEZER -18°/-22°C)	Stainless Steel, Solid Door	LRMR1T	\$15,731	LRMR2T	\$23,977	LRMR3T	\$33,578

SPECIFICATIONS

	1	2	3
CAPACITY 2/1 GN TROLLEY/DOOR	1	2	3
DIMENSIONS - W X D X H MM (HRMR MODELS)*#	905 W x 982 D x 2370 H	1850 W x 982 D x 2370 H	2795 W x 982 D x 2370 H
DIMENSIONS - W X D X H MM (LRMR MODELS)**#	905 W x 982 D x 2460 H	1850 W x 982 D x 2460 H	2795 W x 982 D x 2460 H
DOOR OPENING HEIGHT MM	1776	1776	1776

STANDARD INCLUSIONS ***

DOOR TYPE	SD (Solid Door), Optional: GD (Glass Door - View Panel only)		
FINISH (INTERIOR AND EXTERIOR, EXCLUDES REAR AND UNDER, STAINLESS STEEL INTERNAL FLOOR)	SS (Stainless Steel)		
DOORS	1	2	3

ELECTRICAL

POWER SUPPLY - H/L	10/10 amp	15/15 amp	15/25 amp	
FRIDGE MODELS - SOLID DOORS	RUNNING AMPS	7.0	9.0	10
FREEZER MODELS - SOLID DOORS	RUNNING AMPS	6.5	8.0	20

GAS TYPE

REFRIGERANT	FRIDGE MODELS	R134a	R134a	R134a
	FREEZER MODELS	R404a	R404a	R404a

REFRIGERATION WATTAGES FOR OPTIONAL REMOTE UNITS

FRIDGE MODELS - SOLID DOORS	890 @ -5°C SST	1320 @ -5°C SST	1750 @ -5°C SST
FREEZER MODELS - SOLID DOORS	650 @ -30°C SST	870 @ -30°C SST	650 @ -30°C SST x 2

* does not include floor (HRMR Models)

** L temp height includes 90mm floor (LRMR Models)

All models with internal floors are require to be recessed or an external ramp used

Modular construction—needs to be assembled on site (all models)

*** For **Ruby Roll-in OPTIONS** see page 123

Prices do not include GST. Prices and specifications are subject to change without notice.

Garnet Roll-in

self contained



Electronic controller



Top mounted self contained



Gn trolley compatible



Heavy duty door handle



10 Amp power

The Garnet Roll-in series is a fixed mono block roll-in cabinet that can be configured for a variety of different uses.

Featuring the latest CoolSmart technology, Garnet refrigerated cabinets can operate efficiently in ambient temperatures of up to 43°C.

They are designed to accommodate 1/1 Gn trolleys.



Advantages

- Designed for 43°C ambient environment
- Adjustable electronic controller with digital temperature display
- Self-closing solid door
- Forced air refrigeration system to ensure effective air circulation
- Auto defrost and waste heat recovery vaporiser
- Accommodates 1 x 1/1 Gn size trolley (trolley excluded)
- Top mounted refrigeration system for easy installation and servicing
- Mono block polyurethane construction
- Removable balloon type magnetic door gasket
- Fridge model supplied without floor
- Freezer model supplied with 90 mm insulated floor
- Hydrophilic coated evaporator for higher corrosion resistance properties

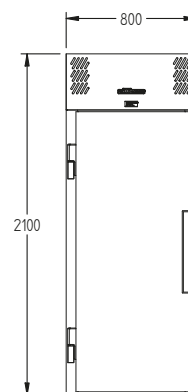
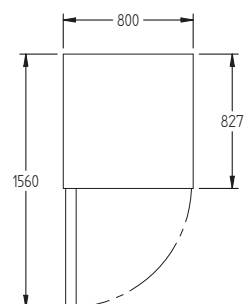
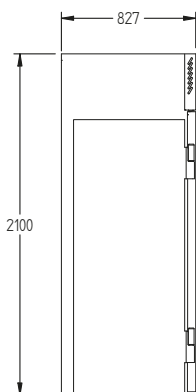

MODEL		1 DOOR	
H (REFRIGERATOR +1°/+4°C)	Stainless Steel, Solid Door	HRG1	\$12,950
L (FREEZER -18°/-22°C)	Stainless Steel, Solid Door	LRG1	\$15,250

SPECIFICATIONS

CAPACITY 1/1 GN TROLLEY	1
DIMENSIONS - W X D X H MM (HRG1 MODEL)*	800 W x 827 D x 2100 H
DIMENSIONS - W X D X H MM (LRG1 MODELS)**	800 W x 827 D x 2190 H
DOOR OPENING HEIGHT MM	1695

STANDARD INCLUSIONS

DOOR TYPE	SD (Solid Door)
FINISH (304 GRADE STAINLESS STEEL INTERIOR AND EXTERIOR, INCLUDES REAR AND UNDER, STAINLESS STEEL INTERNAL FLOOR)	SS (Stainless Steel)
DOORS	1

ELECTRICAL

POWER SUPPLY - H/L	10 amp	
FRIDGE MODELS - SOLID DOORS	RUNNING AMPS	3.8
FREEZER MODELS - SOLID DOORS	RUNNING AMPS	4.3

GAS TYPE

REFRIGERANT	FRIDGE MODELS	R134a
	FREEZER MODELS	R404a

REFRIGERATION WATTAGES FOR OPTIONAL REMOTE UNITS

FRIDGE MODELS - SOLID DOORS	500 @ -5°C SST
FREEZER MODELS - SOLID DOORS	650 @ -30°C SST

* H temp does not include floor (HGR1 Model)

** L temp height includes 90mm floor (LGR1 Model)

All models with internal floors are require to be recessed or an external ramp used

Mono block construction—no assembly on site required (all models)

Prices do not include GST. Prices and specifications are subject to change without notice.

Options

Foodservice specialised

Jarrah
Ruby Roll-in

Mobile Banquet Cart
Amber under counter
Aztra



Right-hand services



Drawers



Standard stainless finish



Gastronorm tray slides



Cylindrical locks



Locking tabs



Extra plastic coated shelf



Stainless steel shelves

OPTIONS	MOBILE BANQUET CART			AMBER			JARRAH		AZTRA		RUBY ROLL-IN		
	MHC10	MHC16-10	MRC16	HA135LP	HA135LPGD	LA135LP	JL2R/JH4R	JL4R/JH6R	HAZ1U	LAZ1U	RMR1T	RMR2T	RMR1T
RH services (services to right hand side)	N/A				N/A		\$215		N/A		N/A		
Solenoid fitted (remote only)	N/A				N/A		\$295		N/A		N/A		
Stainless steel rear & under	N/A				N/A		\$285	\$570	\$185		N/A		
1 Bank FULL drawer set per door	N/A				N/A		N/A		\$1,198	\$1,425	N/A		
2 Bank FULL drawer set per door	N/A				N/A		N/A		\$1,198	\$1,425	N/A		
Cylindrical locks	N/A				\$135		\$270	\$540	\$135		N/A		
Locking tabs	N/A				\$60		\$60	\$120	\$30		N/A		
Extra plastic coated shelf (requires extra slides)	\$57			\$57	\$57	N/A	N/A		\$57		N/A		
Stainless steel shelf upgrade (each)	\$240			\$195	\$195	N/A	N/A		\$195		N/A		
Extra pair of 2/1 Gn slides for shelf pan (per pair)	\$55			N/A			N/A		N/A		N/A		
90mm high floor - H models	N/A				N/A		N/A		N/A		\$300	\$500	\$800
Ramp for 90mm floor (metal checker plate)	N/A				N/A		N/A		N/A		\$1,000	\$1,800	\$2,500
Internal Light	N/A				N/A		N/A		N/A		\$280	\$450	\$650
Roll through (increases depth by 57mm)	N/A				N/A		N/A		N/A		\$1,750	\$3,200	\$4,800

NOTES

- Total height on self contained cabinets includes castors
- Total height on remote cabinets includes legs
- Ramp not available on a Garnet Roll-in unit fridge or freezer
- Optional door hang on Amber (must be advised at time of order). Right hand hinge is standard
- Gas Type: Refrigerator—R134a. Remote Refrigerator—R404a. Freezer—R404a. Remote Freezer—R404a
- Stainless steel interior and exterior except rear and under is standard



General information

Terms + Conditions

WILLIAMS REFRIGERATION AUSTRALIA PTY LTD

ACN 066 630 084

TERMS AND CONDITIONS OF SALE

1. Definitions

In these conditions:

“**ACL**” means the Australian Consumer Law Schedule of the Competition and Consumer Act 2010 (Cth) and its associated Regulations as amended;

“**Agreement**” means any agreement for the provision of goods and/or services by Williams to the Customer;

“**consumer**” is as defined in the ACL and in determining if the Customer is a consumer, the determination is made if the Customer is a consumer under the Agreement;

“**Customer**” means the person, jointly and severally if there is more than one, acquiring goods or services from Williams;

“**goods**” means goods supplied by Williams to the Customer;

“**GST**” means the Goods and Services tax as defined in A New Tax System (Goods and Services Tax) Act 1999 as amended;

“**Intellectual Property**” means all copyright, patents, trade marks, designs, specifications, confidential information, manufacturing processes and all modifications, improvements and derivations (whether registrable or not) owned or licensed by Williams in respect of the goods and services;

“**PPSA**” means the Personal Property Securities Act 2009 (Cth) and its associated Regulations as amended;

“**Price List**” means the price list issued by Williams from time to time;

“**services**” means services supplied by Williams to the Customer;

“**Terms**” means these Terms and Conditions of Sale; and

“**Williams**” means Williams Refrigeration Australia Pty Ltd (ABN 25 006 630 084) of 38-42 Gaine Road, Dandenong South, Victoria, 3175.

2. Basis of Agreement

- 2.1 Unless otherwise agreed by Williams in writing, these Terms and Conditions of Sale apply exclusively to every Agreement and cannot be varied or replaced by any other conditions, including the Customer's terms and conditions of purchase (if any).
- 2.2 Any quotation provided by Williams to the Customer for the proposed supply of goods or services is:
 - (a) valid for 30 days;
 - (b) an invitation to treat only;
 - (c) only valid if in writing.
- 2.3 The Terms may include additional terms in Williams' quotation, which are not inconsistent with the Terms.
- 2.4 An Agreement is accepted by Williams when Williams accepts in writing or electronic means an offer from the Customer or provides the Customer with the goods or services.
- 2.5 Williams in its absolute discretion may refuse to accept any offer.
- 2.6 It is the Customer's responsibility to provide Williams with its specific requirements in relation to the goods and services.
- 2.7 Williams may vary or amend these Terms at any time, with any such changes or amendments notified at www.williamsref.com.au. The Customer acknowledges that they have read the latest Terms prior to placing any order for products.

3. Pricing

- 3.1 Prices quoted, whether in the Price List, by written quotation or verbally, for the supply of goods and services, exclude GST and any other taxes or duties imposed on or in relation to the goods and services. In addition to payment of the price of goods and services, the Customer must pay any GST and any other taxes or duties imposed on the goods and services.

- 3.2 If the Customer requests any variation to the Agreement, Williams may increase the price to account for the variation.
- 3.3 Where there is any change in the costs incurred by Williams in relation to the goods or services, Williams may vary its price to take account of any such change, by notifying the Customer.

4. Payment

- 4.1 Unless otherwise agreed in writing:
 - (a) Payment for the goods and/or services must be made within 30 days of the end of month in which Williams' invoice is raised (Account holders only); and
 - (b) Williams reserves the right to require payment in full prior to the delivery of the goods or completion of the services.
- 4.2 Williams, at its sole discretion, may offer a discount on the price of goods (excluding freight charges) for cash payment.
- 4.3 Payment by cheque is not deemed made until the proceeds of the cheque have cleared.
- 4.4 Merchant or other fees incurred as a result of payment by credit card will be charged to the Customer's account.
- 4.5 Payment terms may be revoked or amended at the sole discretion of Williams immediately upon giving written notice to the Customer.

5. Payment Default

- 5.1 If the Customer defaults in payment by the due date of any amount payable to Williams, then all money which would become payable by the Customer to Williams at a later date on any account, becomes immediately due and payable without the requirement of any notice to the Customer, and Williams may, without prejudice to any of its other accrued or contingent rights:
 - (a) charge the Customer interest on any sum due at the prevailing rate pursuant to the Penalty Interest Rates Act 1983 (Vic) plus 2 per cent for the period from the due date until the date of payment in full;
 - (b) charge the Customer for, and the Customer must indemnify Williams from, all costs and expenses (including without limitation all legal costs, collection agency costs and expenses) incurred by it resulting from the default or in taking action to enforce compliance with the Terms or to recover any goods;
 - (c) cease or suspend supply of any further goods or services to the Customer; and
 - (d) by notice in writing to the Customer, terminate any agreement with the Customer so far as unperformed by Williams.
- 5.2 Clauses 5.1(c) and (d) may also be relied upon, at the option of Williams:
 - (a) where the Customer is a natural person and becomes bankrupt or enters into any scheme of arrangement or any assignment or composition with or for the benefit of his or her creditors or any class of his or her creditors generally; or
 - (b) where the Customer is a corporation and, it enters into any scheme of arrangement or any assignment or composition with or for the benefit of its creditors or any class of its creditors generally, or has a liquidator, provisional liquidator, administrator, receiver or receiver and manager appointed, or any action is taken for, or with the view to, the liquidation (including provisional liquidation), winding up or dissolution without winding up of the Customer.

6. Passing of Property

- 6.1 Until full payment in cleared funds is received by Williams for all goods and services supplied by it to the Customer, as well as all other amounts owing to Williams by the Customer:
 - (a) title and property in all goods remain vested in Williams and do not pass to the Customer;
 - (b) the Customer must hold the goods as fiduciary bailee and agent for Williams;
 - (c) the Customer must keep the goods separate from its goods and maintain the labelling of Williams;

For Williams most current terms and conditions of sale refer to
www.williams-refrigeration.com.au

- (d) the Customer is required to hold the proceeds of any sale of the goods on trust for Williams in a separate account with a bank to whom the Customer has not given security however failure to do so will not affect the Customer's obligation as trustee;
- (e) in addition to its rights under the PPSA, Williams may without notice, enter any premises where it suspects the goods may be and remove them, notwithstanding that they may have been attached to other goods not the property of Williams, and for this purpose the Customer irrevocably licences Williams to enter such premises and also indemnifies Williams from and against all costs, claims, demands or actions by any party arising from such action.

7. Personal Property Securities Act

- 7.1 Notwithstanding anything to the contrary contained in these Terms, the PPSA applies to these Terms.
- 7.2 For the purposes of the PPSA:
 - (a) terms used in clause 7 that are defined in the PPSA have the same meaning as in the PPSA;
 - (b) these Terms are a security agreement and Williams has a Purchase Money Security Interest in all present and future goods supplied by Williams to the Customer and the proceeds of the goods;
 - (c) the security interest is a continuing interest irrespective of whether there are monies or obligations owing by the Customer at any particular time; and
 - (d) the Customer must do whatever is necessary in order to give a valid security interest over the goods which is able to be registered by Williams on the Personal Property Securities Register.
- 7.3 The security interest arising under this clause 7 attaches to the goods when the goods are collected or dispatched from Williams' premises and not at any later time.
- 7.4 Where permitted by the PPSA, the Customer waives any rights to receive the notifications, verifications, disclosures or other documentation specified under sections 95, 118, 121(4), 130, 132(3)(d), 132(4), 135 and 157 of the PPSA.
- 7.5 Williams and the Customer agree to contract out of and nothing in the provisions of sections 96, 125, 129, 142 and 143 of the PPSA will apply to these Terms.
- 7.6 To the extent permitted by the PPSA, the Customer agrees that:
 - (a) the provisions of Chapter 4 of the PPSA which are for the benefit of the Customer or which place obligations on Williams will apply only to the extent that they are mandatory or Williams agrees to their application in writing; and
 - (b) where Williams has rights in addition to those in Chapter 4 of the PPSA, those rights will continue to apply.
- 7.7 The Customer must immediately upon Williams' request:
 - (a) do all things and execute all documents necessary to give effect to the security interest created under this Agreement; and
 - (b) procure from any person considered by Williams to be relevant to its security position such agreements and waivers (including as equivalent to those above) as Williams may at any time require.
- 7.8 Williams may allocate amounts received from the Customer in any manner Williams determines, including in any manner required to preserve any Purchase Money Security Interest it has in goods supplied by Williams.
- 7.9 For the purposes of section 275(6) of the PPSA, the parties agree and undertake that these Terms and any information pertaining to the sale of goods and details of the goods shall be kept confidential at all times. Neither party may disclose any information pertaining to these Terms or the sale of the goods, except as otherwise required by law or that is already in the public domain.

8. Risk and Insurance

- 8.1 The risk in the goods and all insurance responsibility for theft, damage or otherwise will pass to the Customer immediately on the goods being delivered to the Customer from Williams' premises.

- 8.2 The goods are sold to the Customer on the basis that the Customer has obtained all necessary licenses or permits under all relevant laws and regulations in relation to the goods.
- 8.3 The Customer assumes all risk and liability for loss, damage or injury to persons or to property of the Customer, or third parties arising out of the use or possession of any of the goods sold by Williams, unless recoverable from Williams on the failure of any statutory guarantee under the ACL.

9. Acknowledgments

- 9.1 It has not made known, either expressly or by implication, to Williams any purpose for which it requires the goods or services and it has the sole responsibility of satisfying itself that the goods or services are suitable for the use of the Customer.
- 9.2 The Customer acknowledges that:
 - (a) it has not relied on any service involving skill and judgement, or on any advice, recommendation, information or assistance provided by Williams in relation to the goods or services or their use or application;
 - (b) any description of the goods provided in a quotation or invoice is given by way of identification only and the use of such description does not constitute a contract of sale by description.
 - (c) it must provide to Williams full particulars of its requirements, including but not limited to, its ABN, order number, quantity and model number and any options required, delivery date, delivery address, insurance instructions and freight instructions, before Williams will accept any order.

10. Performance of Agreement

- 10.1 Any period or date for delivery of goods or provision of services stated by Williams is intended as an estimate only and is not a contractual commitment. Williams will use its reasonable endeavours to meet any estimated dates for delivery of the goods or completion of the services but will in no circumstances whatsoever be liable for any loss or damage suffered by the Customer or any third party for failure to meet any estimated date.
- 10.2 A completed drivers manifest or delivery docket whether signed by the driver or by the Customer or its employee or agent will be proof of delivery of goods invoiced.

11. Delivery

- 11.1 Williams will nominate and coordinate a carrier on the Customer's behalf unless otherwise instructed by the Customer.
- 11.2 The Customer will inform Williams of all necessary details so that Williams can affect the delivery of the goods.
- 11.3 The Customer may nominate its own carrier, in which case it must coordinate the delivery with Williams.
- 11.4 Unless otherwise agreed in writing, the Customer will be responsible for all costs associated with delivery, including any special packaging or required crating, freight, insurance and other charges arising from the point of despatch of the goods to the Customer to the point of delivery.
- 11.5 The Customer must provide reasonable and proper access to the location specified for delivery.
- 11.6 Any extra carrier charges due to difficult access, wrong or misleading instructions provided by the Customer, frustrated delivery, or the requirement for extra personnel, will be charged to Customer at cost plus a 10% service fee plus GST charged by Williams.
- 11.7 The obligation of Williams to deliver goods shall be satisfied by the delivery by Williams of the quantity of goods ordered or if delivery is by instalments, by the delivery of the quantity of goods to be delivered in each instalment (+/- 10%). The Customer shall only be required to pay for the actual quantity of the goods delivered by Williams.
- 11.8 If Williams does not receive forwarding instructions sufficient to enable it to despatch the goods within 14 days of notification that the goods are ready, the

Terms + Conditions

Customer shall be deemed to have taken delivery of the goods from such date. The Customer shall be liable for storage charges payable monthly on demand.

- 11.9 Where it is necessary for Williams to deliver the goods in other than a fully assembled condition (which facts will be stated in the quotation), the cost and responsibility of assembly and installation will fall to the Customer.
- 11.10 The Customer must advise Williams in writing within 3 days of receipt:
- (a) of the non arrival of any or all of the goods;
 - (b) if there is damage to the goods;
 - (c) that the wrong goods have been received;
 - (d) that the quantity of the goods is incorrect; or
 - (e) the goods do not meet specifications.

12. Returns

- 12.1 Goods may only be returned to Williams:
- (a) if the request to return is made in writing to Williams within 3 days of delivery to site, stating reason for the requested return;
 - (b) if the goods are not optioned or customised in any way or produced to a specific Customer requirement in part or in whole;
 - (c) with the prior written authority of Williams;
 - (d) if the Customer pays for all transport and handling costs to Williams' warehouse;
 - (e) if the goods are accompanied by a copy of the Williams GRA provided as proof of authorisation in accordance with clause 12.1(c);
 - (f) on the acceptance of the application of a restocking and handling charge, such charge being a minimum of 20% of the invoice value, except where the wrong goods were delivered by Williams, in which case there will be no restocking or handling charge; and
 - (g) if the goods are in an undamaged and unsoiled condition and in the original packaging, unless with the prior written consent of Williams.

13. Cancellation

- 13.1 If Williams is unable to deliver or provide the goods or services, then Williams may cancel the Customer's order (even if it has been accepted) by written notice to the Customer.
- 13.2 No purported cancellation or suspension of an order or any part thereof by the Customer is binding on Williams after that order has been accepted.
- 13.3 Williams, in its absolute discretion may review, alter or terminate the Customer's credit limit or payment terms without notice.
- 13.4 If the Customer cancels the order after acceptance by Williams, then Williams will be entitled to damages for breach of contract. This includes, but is not limited to, compensation in accordance with Williams' Order Cancellation Policy as in effect at time of Order Confirmation.

14. Specifications

- 14.1 All specifications, drawings, illustrations descriptive matter and particulars contained in Williams' catalogues, website and marketing documents are indicative only, do not form part of this Agreement, and are not representations or warranties of any kind. Any discrepancy will not entitle the Customer to rescind this Agreement or seek compensation or damages.
- 14.2 Williams reserves the right to make minor modifications to its goods without notice to the Customer and deliver such modified goods against any existing order, unless such right is waived by Williams in writing to the Customer.
- 14.3 The Customer must not reverse engineer any goods provided to it by Williams.
- 14.4 All drawings, descriptive matter and particulars supplied, remain Williams' property and are to be returned to Williams on demand. The Customer must not publish or communicate any of them to any person or publish or permit them to be copied or communicate them to any other person without Williams' prior consent in writing.

15. Intellectual Property

- 15.1 The Customer acknowledges that it has no proprietary right or interest in the Intellectual Property.
- 15.2 The Customer must not register or record or attempt to register or record anywhere in the world the Intellectual Property or any part or any patents, inventions, trade marks or designs derived from or similar to the Intellectual Property or aid or abet anyone else in doing so.
- 15.3 The Customer must not at any time create, sell, manufacture or process any goods or services using or taking advantage of the Intellectual Property.
- 15.4 Any Intellectual Property provided to the Customer by Williams in connection with the goods and services remains the exclusive property of Williams and must be returned to Williams on demand and must not be copied or communicated to any third party without the express written consent of Williams.

16. Liability / Warranty

- 16.1 Except as the Terms specifically state, or as contained in any express warranty provided in relation to the goods or services, the Agreement does not include by implication any other term, condition or warranty in respect of the quality, merchantability, acceptability, fitness for purpose, condition, description, assembly, manufacture, design or performance of the goods or services or any contractual remedy for their failure.
- 16.2 Williams products are not designed for nor have the appropriate certifications, licences or accreditations for use in personal, domestic or household applications. The Customer warrants that Williams products will not be used for such applications. To the extent permitted by law, Williams specifically does not warrant its products used in such applications.
- 16.3 If the Customer is a consumer nothing in these Terms restricts, limits or modifies the Customer's rights or remedies against Williams for failure of a statutory guarantee under the ACL.
- 16.4 If the Customer on-supplies the goods to a consumer and:
- (a) the goods or services are not of a kind ordinarily acquired for personal, domestic or household use or consumption, then the amount specified in section 276A(1) of the ACL is the absolute limit of Williams' liability to the Customer;
 - (b) the goods or services are of a kind ordinarily acquired for personal, domestic or household use or consumption, payment of any amount required under section 274 of the ACL is the absolute limit of Williams' liability to the Customer; howsoever arising under or in connection with the sale, installation, use of, storage or any other dealings with the goods or services by the Customer or any third party.
- 16.5 If clause 16.2 or 16.4 do not apply, then other than as stated in the Terms or any written warranty statement Williams is not liable to the Customer in any way arising under or in connection with the sale, installation, use of, storage or any other dealings with the goods or services by the Customer or any third party.
- 16.6 Williams is not liable for any indirect or consequential losses or expenses suffered by the Customer or any third party, howsoever caused, including but not limited to loss of perishables, loss of turnover, profits, business or goodwill or any liability to any other party except to the extent of any liability imposed by the ACL.
- 16.7 Nothing in the Terms is to be interpreted as excluding, restricting or modifying or having the effect of excluding, restricting or modifying the application of any State or Federal legislation applicable to the sale of goods or supply of services which cannot be excluded, restricted or modified.
- 16.8 Where the Customer is a consumer, the following mandatory statement applies: Our goods come with guarantees that cannot be excluded under the Australian Consumer Law. You are entitled to a replacement or refund for a major failure and for compensation for any other reasonably foreseeable loss or damage. You are also entitled to have the goods repaired or replaced if the goods fail to be of acceptable quality and the failure does not amount to a major failure.
- 16.9 Williams warrants, subject to the exclusions and limitations below, the goods will be free from defects in materials and workmanship for the applicable warranty period set out below ("Warranty").

For Williams most current terms and conditions of sale refer to
www.williams-refrigeration.com.au

- 16.10 Subject to the remainder of clause 16, Williams, in its reasonable discretion if it deems necessary, will repair or replace any goods to remedy any fault covered by Warranty, provided that:
- (a) the goods may have acceptable variance; and
 - (b) any replacement or repaired goods will only be warranted for the unexpired portion of the Warranty period attached to the original goods.
- 16.11 Unless stated otherwise, our standard warranty period and product covered is;
- (a) Self-contained units, 24 months from our original invoice date;
 - (b) Units connected to a remote condenser, 12 months parts only warranty from our original invoice date;
 - (c) Spare parts, 3 months from our original invoice date.
- 16.12 Provision of the Warranty is subject to:
- (a) the Customer not being in breach of these Terms or any additional Agreement as may be in place;
 - (b) proof of purchase of the goods being directly from Williams or an authorised distributor or agent of Williams;
 - (c) Williams' or its representative, at its option, having access to the goods for the purposes of inspection and verification of any claim;
 - (d) the Customer accepting an invoice for any replacement parts claimed under Warranty, which will be reimbursed, excluding freight costs, only after confirmation of the claim by Williams;
 - (e) the full payment of any invoices rendered by Williams to the Customer for non Warranty work;
 - (f) the Customer has not repaired or undertaken to repair the goods without prior authorisation from Williams nor altered the goods in any way;
 - (g) the Customer uses and maintains the goods in accordance with Williams' instructions and in accordance with commonly accepted operating practices;
 - (h) the Customer providing written notice within 3 days of delivery of any goods that it believes do not meet specifications or goods that are defective; and
 - (i) correct storage, siting and installation of the goods in accordance with Williams' instructions.
- 16.13 The following Warranty exclusions apply:
- (a) any product which Williams publishes as excluded from application of this Warranty;
 - (b) any product for which the Warranty period published by Williams (in advertising material or otherwise) differs from the Warranty period outlined above;
 - (c) defects or malfunctions that are the result of incorrect or poor maintenance by the Customer;
 - (d) damage or alteration to the goods arising from circumstances outside the direct control of Williams, including, without limitation, power surges, disruptions, flooding, fire or acts of god or where the goods are not used for their intended purpose;
 - (e) any part of a refrigeration cabinet which has been subject to misuse, neglect, alteration or changed in any manner, incorrect installation or accident that has been caused by the Customer or its invitee;
 - (f) the failure of goods that have been supplied to a Customer's specification or design and that failure was caused by a Customer specification or design fault;
 - (g) any problem that might arise due to poor installation or siting of the goods, including but not limited to, lack of sufficient fresh air circulation, marine or mobile applications;
 - (h) any problem that might arise out of the installation of remote cabinets, including but not limited to, blockages or leaks in the refrigeration system, replacement refrigerant and components including TX valves, and wiring issues with controllers;
 - (i) any third party equipment that the Customer might have specified;
 - (j) any installation or removal costs necessary to access or service the goods;
 - (k) any time spent on security clearance, inductions and suchlike;
 - (l) damage to, or breakage of, glass doors, gaskets, power leads, hinges, lights or plastic components; and
 - (m) the failure of gaskets, lights, hinges, locks, TX valves and batteries.
- 16.14 Williams reserves the right to replace defective parts of the goods with parts and components of similar quality, grade and composition where an identical part or component is not available.
- 16.15 Goods presented for repair may be replaced by refurbished goods of the same type rather than being repaired. Refurbished parts may be used to repair the goods.
- 16.16 The Customer warrants to use the goods in accordance with:
- (a) any instructions provided to it by Williams from time to time;
 - (b) all government and local regulations, including but not limited to all relevant environmental laws and regulations governing the storage, installation, use, handling, maintenance and disposal of the goods.
 - (c) all necessary and appropriate precautions and safety measures relating to the storage, installation, use, handling and maintenance of the goods.
 - (d) Williams' approved Warranty work undertaken by authorised service agents is arranged during our normal working hours only (generally Monday – Friday, 8am to 4.30pm, excluding public holidays).
- 16.17 The Customer bears the cost of making the Warranty claim.
- 16.18 Approved Warranty repair work will be conducted for free only on the Australian mainland and within 50kms of a Williams Authorised service agent premises. If the Customer is located more than 50km away, then any distance will be charged to the Customer on the excess at commercial rates.
- 16.19 Williams makes no express warranties or representations other than as set out in this clause 16.
- 16.20 The repair or replacement of the goods or part of the goods is the absolute limit of Williams' liability under the Warranty.
- 16.21 The benefits of this Warranty are in addition to any rights and remedies imposed by Australian State and Federal legislation that cannot be excluded.
- 16.22 In the case of goods not manufactured by Williams but are sourced from third parties and supplied by Williams, this Warranty will not operate to extend the terms of the original manufacturer of those goods.
- 16.23 Our contact details are:
- Williams Refrigeration Pty Ltd**
38-42 Gaine Road
Dandenong South, Victoria, 3175
Ph: 03-8787 4747
Fax: 03-8787 4787
Email: wrasupport@williamsref.com.au
- ## 17. Miscellaneous
- 17.1 The law of Victoria from time to time governs the Terms. The parties agree to the non-exclusive jurisdiction of the courts of Victoria, the Federal Court of Australia, and of courts entitled to hear appeals from those Courts.
- 17.2 Failure by Williams to enforce any of these Terms shall not be construed as a waiver of any of Williams' rights.
- 17.3 If any of the Terms are unenforceable it shall be read down so as to be enforceable or, if it cannot be so read down, the condition shall be severed from these Terms without affecting the enforceability of the remaining conditions.
- 17.4 A notice must be in writing and handed personally or sent by facsimile, email or prepaid mail to the last known address of the addressee. Notices sent by pre-paid post are deemed to be received upon posting. Notices sent by facsimile or email are deemed received upon confirmation of successful transmission.

Warranty + Policy



Warranty Claim Notes

- All warranty claims must be logged with and authorised by Williams prior to any work being carried out.
- Williams approved warranty work undertaken by authorised service agents is arranged during our normal working hours only (generally Monday – Friday, 8am – 4.30pm, excluding public holidays).



Commercial Refrigeration Equipment in Domestic Applications Policy

From time to time our company is asked by dealers and other customers whether our equipment can be used in domestic applications.

Please note the following:

All refrigeration products sold for domestic use in Australia and New Zealand must meet a range of *Mandatory* and *Legislated* standards. This is a legal requirement in all states and territories.

Many of the standards applicable to domestic appliances require independent, third party accreditation to a range of tests specifically and uniquely applicable to domestic equipment.

The specific legislation covering the sale and supply of equipment intended for domestic use differs substantially from that applicable to Commercial Refrigeration equipment in a wide number of areas from electrical safety requirements through to mandatory energy star rating schemes.

Williams Refrigeration Australia specifically does not warrant its commercial refrigeration equipment for use in these domestic applications nor does it represent that it will comply with applicable standards requirements or that it has any of the appropriate certifications or accreditations for these applications.

Similarly, Williams Refrigeration design envelopes and performance goals do not include the fit, finish, noise and other customer demands of domestic applications.

For this reason, it has always been, and remains the policy of Williams Refrigeration Australia that its Commercial Refrigeration equipment should not be sold or supplied for any such domestic applications.

Model Codes explained

H TEMPERATURE		O MODEL		1 DOORS	U CONDENSER	FBBA STANDARD OPTIONS		VARIATIONS
H	Fridge (1 / 4°C)	GENERAL UPRIGHTS		1	U Self contained	G/GD S/SD	Glass Door Solid Door	
CF	Chilled food (0 / 3°C)	D	Diamond	2	R Remote	BA	Blown Airwell (counters)	
M	Meat fridge (-2 / 2°C)	P	Pearl	3		W/CB B/CBB S/SS	White Black Stainless Steel	
W	Wine (5 / 16°C)	R	Ruby	4		SC/PC	Sandwich / Pizza Counter (Jade)	
L	Freezer (-18 / -22°C)	QS	Quartz Star	5		HC	Hydrocarbon	
FL	Flower Fridge (1 / 4°C)	Q	Quartz					
R	Retarder (-5 / 3°C)	FOODSERVICE UPRIGHTS						
V	Vari Temp (1 / -22°C)	G	Garnet					
		S	Sapphire					
		FOODSERVICE COUNTERS						
		O	Opal					
		E	Emerald					
		HYDROCARBON						
		J	Jade Hydrocarbon					
		O	Opal Hydrocarbon					
		MAR	Meat Aging Refrigerator					
		AZ	Aztra Hydrocarbon					
		V	Vari Temp Drawer					
		A	Amber Hydrocarbon					
		BAKERY						
		OB	Opal Bakery					
		GB	Garnet Bakery					
		CT	Crystal					
		PREPARATION COUNTERS						
		J	Jade Sandwich / Pizza					
		SP	Banksia					
		TW	Thermowell					
		GENERAL COUNTERS + BACK BARS						
		B	Boronia					
		C	Cameo					
		GC	Glass Chiller					
		FGC	Glass Chiller Slimline					
		BC	Bottle Cooler / Wine Cabinet					
		TOPAZ CAFE RANGE						
		TG	Topaz Top Mount					
		TU	Topaz Under Counter					
		TCF / TCFH	Topaz Cake and Food display					
		TM	Topaz Milk					
		TB / TD	Topaz Bottle Cooler					
		BLAST CHILLER/FREEZERS		FOODSERVICE SPECIALISED				
		WBCF	Blast Chiller / Freezer reach in	MHC/MRC	Mobile Banquet Cart			
		WMBC	Blast Chiller roll in 700 mm door	A135	Amber under counter			
		WMBCF	Blast Chiller / Freezer roll in 700 mm door	AZ1U	Aztra			
		WMBF	Blast Freezer roll in 700 mm door	JL/JH	Jarrah			
		WMBCC	Blast Chiller roll in 900 mm door	UBC	Under Broiler Counter			
		WMBFCF	Blast Chiller / Freezer roll in 900 mm door	RMR	Ruby Modular Roll-in			
		WMBFC	Blast Freezer roll in 900 mm door	RG	Garnet Roll in			



WILLIAMS-REFRIGERATION.COM.AU

Williams Refrigeration Australia Pty Ltd

Australian Head Office

38-42 Gaine Rd Dandenong South VIC 3175
PO Box 4195 Dandenong South BC VIC 3164

P 03 8787 4747
F 03 8787 4787
E sales@williamsref.com.au

FREECALL 1800 338 148

WARRANTY 03 8787 4712

SPARE PARTS 03 8787 4713