



# OPERATING MANUAL FOR GEM MULTIDECK DISPLAY CABINETS

## IMPORTANT INFORMATION (PLEASE RETAIN THIS DOCUMENT)

This Manual covers the installation, operation and routine maintenance requirements for the following Williams Refrigeration products:

### R-Series / M-Series

A refrigerated display cabinet is designed to maintain the temperature of pre-chilled produce within the temperature range set out below.

Please read this Manual carefully before connecting the appliance.

Provided the instructions in this Operating Manual are read and implemented correctly, the optimum performance and reliability of your equipment should be maintained.

We assume the installer, user and service provider are appropriately trained, skilled and competent to properly and safely carry out the work, and will use the necessary safety equipment, and take the necessary precautions required of their intended work.

Improper installation, maintenance or repair may put the user at considerable risk.

GEM Temperature Range	GEM Climate Class	GEM dB(A)
+3°C(37°F) / +5°C (41°F)	3M2*	70

**\*Models with a product code suffix 'MT' are classified in product Class 3M1.**

## General Regulations

### Declaration of Conformity & TUV Registered:



Refrigerant Designation	Global Warming Potential
HFC - R404a	3922
HFC/HFO - R452a	2140 (Not TUV Certified)
HC - R290	3

Williams Refrigeration declares that all products manufactured by Williams Refrigeration comply with the above directives as they apply to those products, and those products are therefore declared to be in conformity with the provisions of the above legislation.

Model No.: .....

Serial No.: .....



# INDEX

---

IMPORTANT REFRIGERATION AWARENESS	PAGE 3
INSTALLATION	PAGES 4-6
CONTROLLER	PAGE 7
ROUTINE MAINTENANCE / CLEANING	PAGES 8-9
TROUBLE SHOOTING	PAGE 9
R290 WIRING DIAGRAM	PAGE 10
GENERAL WIRING DIAGRAMS	PAGES 11-13
WARRANTY	PAGES 14-15

---

## KEY SAFETY CONSIDERATIONS

- The Maximum evenly distributed shelf load weights are: Glass: 20kg  
Metal: 40kg
- Only fit a new light tube of the same specification and wattage.
- Please note the further safety advice in respect of the movement, maintenance and safe disposal of this appliance.
- Appliances can be equipped with a remote condensing unit. Sizing, selection and installation of the remote condensing unit must be undertaken by a competent and qualified refrigeration engineer.

---

## IMPORTANT SAFETY INFORMATION

---

**Warning:**

Do not store explosive substances such as aerosol cans with a flammable propellant in this appliance.

**Warning:**

Do not use electrical appliances inside the food storage compartments of this appliance.

**Warning:**

Keep ventilation openings of the appliance enclosure or the structure of built in equipment, clear of obstruction.

**Warning:**

Do not use mechanical devices or other means to accelerate the defrosting process.

**Warning:**

Do not damage the refrigerant circuit, i.e. pipe work or components.

### ELECTRICAL



The appliance must be disconnected from its power source during cleaning; when maintenance and the replacement of parts is required, the equipment must be safely disconnected and isolated from the power supply using a lock-off system at the isolation device.



It is advised that the electrical supply to the equipment is protected by an appropriately selected Residual Current Device (RCD) with a rating no greater than 30mA.



If the supply cord is damaged, it must be replaced by a service engineer or other qualified person. Only the supply cord supplied by Williams Refrigeration must be used.



Fixed wiring appliances (those not supplied with a plug) shall incorporate a switch disconnector to meet the specification of IEC 60947; this is to be installed within the fixed wiring installation in accordance to the local wiring rules / regulation to provide all pole disconnection of the power supply.

## IMPORTANT REFRIGERATION AWARENESS FOR SYSTEMS CHARGED WITH FLAMMABLE REFRIGERANTS

# WARNING



### SYSTEM CHARGED WITH FLAMMABLE REFRIGERANT

#### REFRIGERANT: R290 (REFRIGERANT GRADE PROPANE ONLY)

Ensure all operatives are aware the appliance contains an environmentally friendly but flammable refrigerant.

#### Technical Safety and Advice

All appliances are only to be installed by persons who are appropriately trained, skilled and competent to properly and safely carry out the work, and serviced by qualified engineers for the handling of hydrocarbon refrigerants

Ensure procedures are adhered to in the following Operating Manual.

**Should a suspected leak become apparent, immediately evacuate the area and remotely switch off the cabinet.**

**DO NOT remove the plug from the socket as this could act as a source of ignition. Leaking refrigerant may ignite and cause injuries.**

Keep ventilation openings in the appliance enclosure or in the structure clear of obstruction.

Contact Williams Refrigeration on +44 (0) 1553 817 000, stating the suspected fault.

# INSTALLATION

## SAFE REMOVAL & DISPOSAL OF REDUNDANT APPLIANCES

Refrigeration appliances contain refrigerant and gases in their insulation and must be disposed of professionally by a licensed waste management contractor.

Please ensure that old or redundant refrigeration appliances are disposed of safely and legally. It is recommended that doors are removed prior to disposal in order to ensure safety.

## UNPACKING

Care should be taken during the unpacking process as the appliance could be temporarily unstable. Installation and unpacking should only be undertaken by a competent person.

Remove all external and interior packing and accessories. Ensure all such material is disposed of safely.

Check that no damage has occurred to the appliance, the tubing of the refrigeration system, power cable and plug top during transit. If damage has occurred do not use the appliance.

We recommend that prior to use, the appliance is cleaned with a mild soap solution and then wiped dry.

## VENTILATION

The appliance should be installed in a dry place, avoiding direct exposure to sunlight and sources of heat or draughts including air currents such as radiators, fans, air conditioning units and doors etc. It is essential to ensure that the room in which the equipment is installed is adequately ventilated.

Multidecks generate a considerable amount of heat and, if operated in a small unventilated room will quickly cause the room temperature to become excessive. This could cause the motor to overheat and possibly damage the compressor. At the very least, such an installation will cause the unit to use an excessive amount of electricity.

In addition to ventilation in a room, please ensure, if positioned against a wall, there is a clearance at the back of the appliance of at least 80mm for the condensing unit to operate effectively and efficiently.

**Do not block vents by stacking boxes on top or in front of the unit as this could affect performance and give rise to safety risk.**

## REMOTE REFRIGERATION SYSTEMS

Appliances can be equipped with a remote condensing unit. Sizing, selection and installation of the remote condensing unit must be undertaken by a competent and qualified refrigeration engineer.

A separate power supply is needed for the remote condensing unit.

## CASTORS & ADJUSTABLE POSITIONING FEET

The appliance should stand level to ensure the correct operation.

The appliance is fitted with castors as standard. When the appliance has been positioned please ensure the adjustable feet are fixed in position into the rear of the base frame.

## MAINS CONNECTION

**Commercial kitchens and foodservice areas are environments where electrical appliances may be located close to liquids, or operate in and around damp conditions or where restricted movement for installation and service is evident.**

Great care must be exercised at all times when installing, operating, or servicing this appliance.

For appliances fitted with a moulded plug for safety, ensure that the mains power cable is extended free from the refrigeration system to avoid entanglement. If a plug or mains cable requires replacement, contact the Williams Spares Office on +44(0)1553 817017.

The installation of a fixed appliance and periodic inspection should only be undertaken by a qualified, skilled, and competent electrician; and connected to the correct power supply suitable for the load as stipulated by the appliance data label.

The electrical installation and connections should meet the necessary requirements to the local electrical wiring regulations and any electrical safety guidelines.

All appliances rely upon a suitable connection to earth to ensure safe operation. If in doubt, contact a qualified, skilled, and competent electrician before using the appliance.

## We recommend:-

- **Supplementary electrical protection with the use of a residual current device (RCD)**
- **Fixed wiring appliances incorporate a switch disconnector for purposes of safe isolation to meet the specification requirements of IEC 60947**

**If the appliance has been laid on its back or tipped, DO NOT switch on immediately. Leave in an upright position for at least 3 hours before switching on.**

## SHELF / SLIDE FITTING

Ensure all shelves are fitted so they are in contact with the back panel.

To adjust the position of the trayslides insert the ends into the vertical support with the 'hooks' pointing downwards and slot into position. Ensure trayslides are parallel and level after fitting.

## SHELF WEIGHT DISTRIBUTION

**Before loading, allow the appliance to reach its normal operating temperature.**

When loading the appliance, please ensure that its load is equally distributed throughout and ensure a gap of 80mm between products and the shelf above, to ensure effective air circulation. (See Fig. 1)

The maximum evenly distributed shelf load weights are:

Glass: 20kg

Metal: 40kg

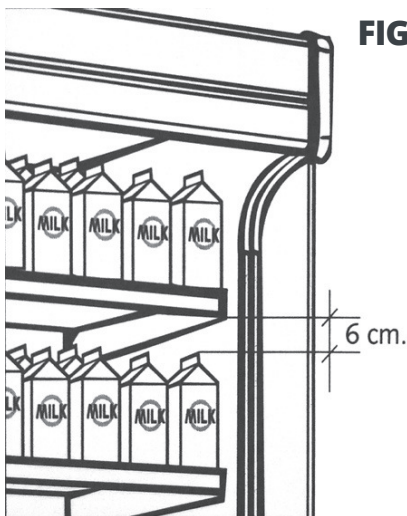

**FIG 1.**

## LOCKING FACILITY

On models with a locking facility, it is recommended that the key be removed from its lock during normal working use. This will prevent bending or breaking of the key which could result in the lock having to be replaced.

## NIGHT BLINDS AND ROLLER SHUTTERS

To help conserve energy, maintain product temperature and conceal product from view during out of hours operation, a night blind or roller shutter can be selected.

### Night Blind

The night blind is positioned by pulling down in a single smooth motion and hooked in place. To open the blind, pull it slightly down and release. The soft close mechanism will then slowly retract the blind into its upper location.

### Roller Shutters

The roller shutter incorporates a lock to secure the Multideck when not in retail service. To operate the roller shutter pull down in a level and single motion. The roller shutter is retracted by being pushed upwards. Keys should be retained in a safe and secure location.

## SAFE STORAGE AND DISPLAY

The appliance should not be used to store or display flammable or explosive substances including aerosols.

A refrigerated display cabinet is designed to hold the temperature of pre chilled and packaged foods and beverages. Please ensure produce is at its desired temperature before loading into the display cabinet.

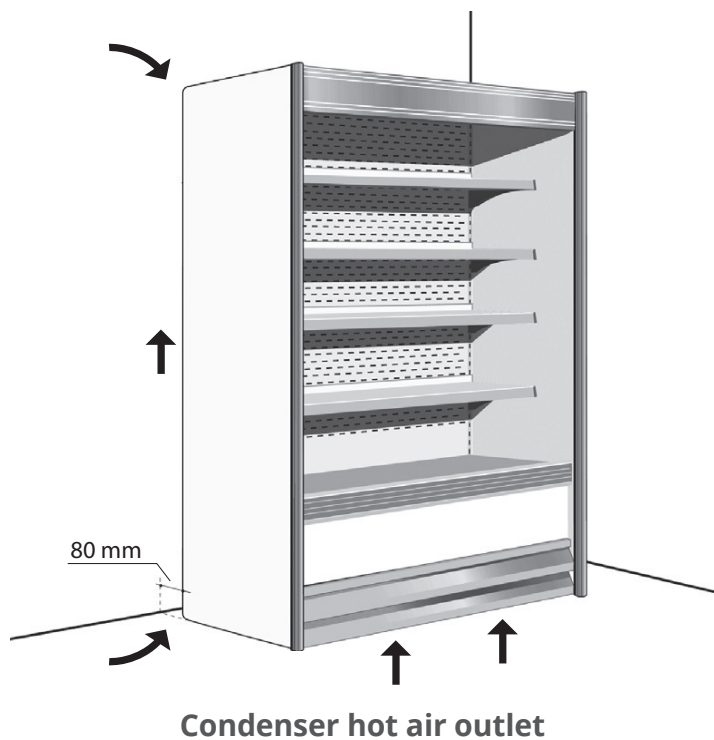

### SPACERS FIXING

Before positioning the Multideck be sure that the two spacers are fixed to the base.

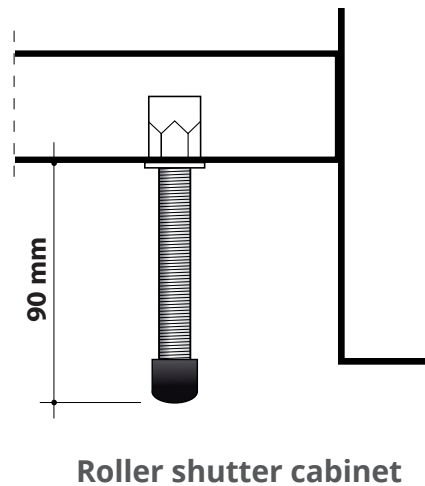
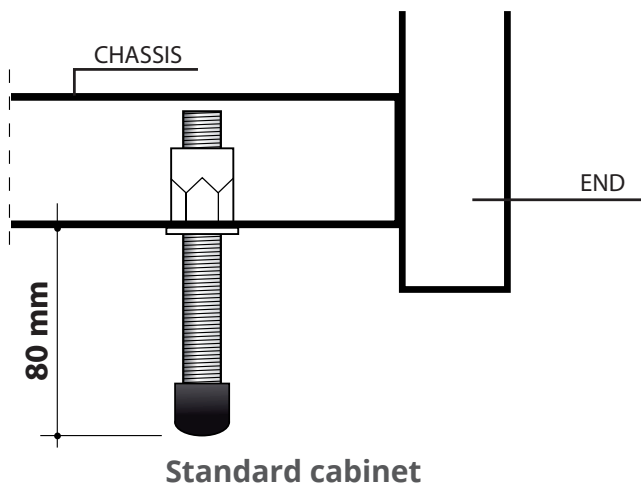
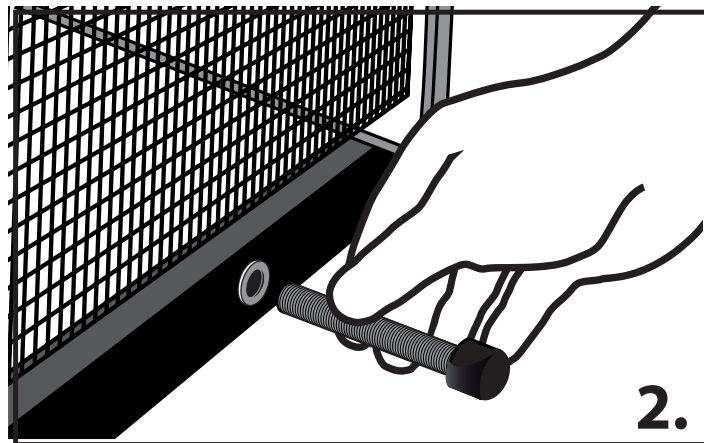
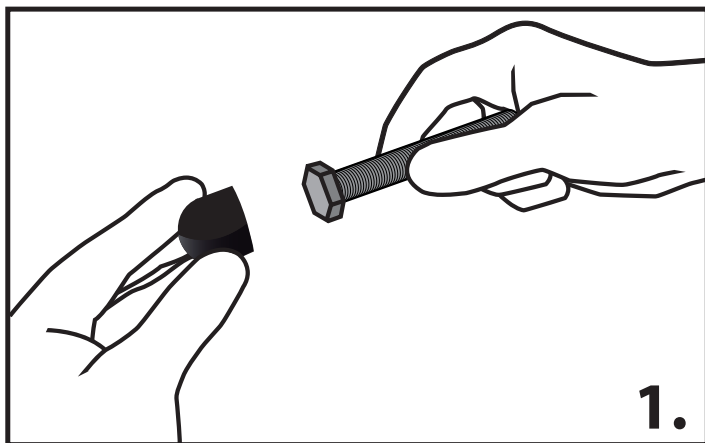
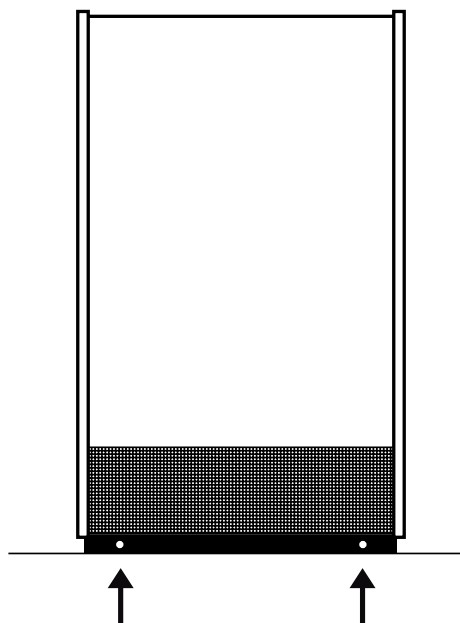

# CONTROLLER

## CONTROLLER / DISPLAY

The display should be checked daily to ensure that the correct temperature is being maintained.

## CONTROLLER

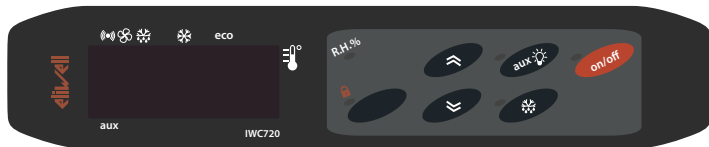

### Switching on your appliance

Switch the appliance on by pressing and holding for 2 seconds the ON/OFF button.

**We recommend the night blind or security shutter be used overnight or when the Multideck is not in use to save on electricity.**

### Key to Controls

- SET** To display target set point; in programming mode to select a parameter or confirm an operation.
- (DEF)** To start a manual defrost.
- (UP)** To see the maximum stored temperature; in programming mode to browse the parameter code or increase the displayed value.
- (DOWN)** To see the minimum stored temperature; in programming mode to browse the parameter code or decrease the displayed value.

## ADJUSTING THE OPERATING TEMPERATURE

To access the parameters press the **"SET"** key, then select the required parameter in the following sequence:

- Press the **"SET"** key to display its value
- Use the **"UP"** or **"DOWN"** keys to change its value
- Press **"SET"** to store the new value and move to the next parameter

**To exit:** If you press **"SET"**, **"fnc"** or a time of 15 seconds elapses, the last value displayed will be saved and the label **"SET"** will reappear on the display.

The set value is stored even when the procedure is exited by waiting for the time-out to expire. To adjust the operating temperatures, press and hold the **"SET"** key for more than 3 seconds, while the maximum or minimum temperature is displayed.

**NB:** All appliances are preset at the factory. However, conditions on site will vary compared with test conditions and it may be necessary to perform the above adjustments several times for a perfect temperature cycle.

## DEFROST OPERATION

Push the **"DEF"** key for 2 seconds to activate a manual defrost.

**dit** **Interval between defrost cycles:** (0/250h). Determines the time interval between the beginning of the two defrost cycles.

**dEt** **Length for defrost:** (0/250mins) It sets the defrost duration



# APPLIANCE ROUTINE MAINTENANCE / CLEANING

## ROUTINE MAINTENANCE

Safely disconnect the appliance from the power supply before cleaning, servicing or undertaking general maintenance.

We recommend that you undertake regular preventative maintenance using a qualified service provider in order to get the best from your equipment.

## CLEANING

Always wear appropriate personal protective equipment (PPE) when cleaning the appliance. Care should be taken for parts with possible sharp edges.

NB: Abrasive or corrosive materials / cleaners should never be used. This includes chlorine based chemical cleaners. These can damage surfaces and cause corrosion.

If the cabinet exterior is looked after correctly it will retain an "as new" finish for many years. Normal day to day cleaning should be carried out with a soft cloth and soapy water. If the product's exterior has a stainless steel finish occasionally use a good stainless steel polish for protection. Do not wash the cabinet with a hose or spray. (Fig.2).

Shelving can be removed for easy cleaning, cabinet interior should be cleaned regularly with warm soapy water and a soft cloth.

Dry thoroughly afterwards.

### FIG 2.

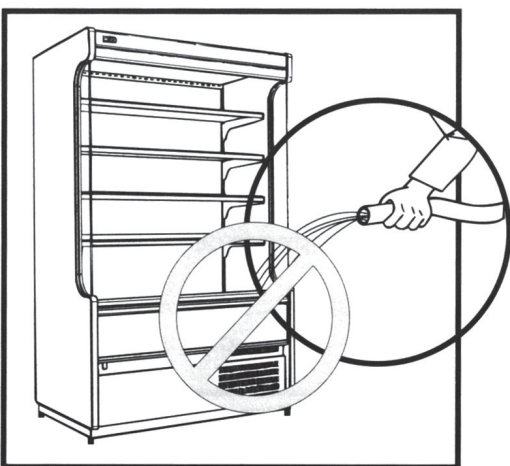

## CONDENSER CLEANING

Regular maintenance should be carried out by competent / trained personnel. The condenser is part of the refrigeration unit and is located in the unit compartment and requires cleaning, approximately every two months.

To achieve access to the condenser you must remove the front grill. (Fig.3)

### FIG 3.

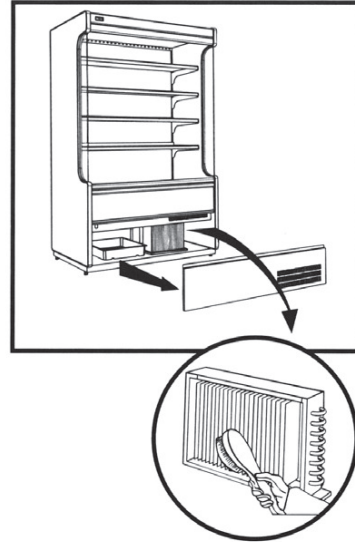

Brush fins vertically with a stiff brush, taking care not to damage them or to push dirt / dust further in, and then vacuum away.

Remember to reconnect the mains supply once finished.

If there are further grease deposits still remaining on the condenser call your Service Provider to carry out a full service.

### NB: Non-compliance may invalidate your Warranty.

Take care not to damage any electrical connections and cables during removing and the cleaning process.

## REPLACING THE LIGHTING LAMP (HORIZONTAL ILLUMINATION)

- Disconnect the appliance from the electrical supply by unplugging it.
- Carefully remove the plastic lens cover to expose the light tube.
- Turn the light tube and remove it from the lamp holder.
- Fit the new lamp tube and carefully replace the plastic lens cover. Only fit a new light tube of the same specification and wattage.
- Reconnect the mains supply once finished.

- Safely handle and dispose of the redundant light tube.

### REPLACING THE LIGHTING LAMP (VERTICAL ILLUMINATION)

- Disconnect the appliance from the electrical supply by unplugging it.
- Carefully remove the plastic lens cover to expose the light tube.
- Note and carefully remove the light tube from the two small support clips.
- Fit the new lamp tube with the two small support clips.
- Reconnect the mains supply once finished.
- Safely handle and dispose of the redundant light tube.

### BREAKDOWN

In the event of a breakdown, please contact Williams Refrigeration or your Service Provider

When calling, please advise model and serial number. This information can be found on the data plate. It should also be noted on the cover of this Manual. Please ensure that all redundant parts are disposed of safely and legally.

### TROUBLE SHOOTING INFORMATION

<b>Fault Display</b>	<b>Possible Cause</b>	<b>Action</b>
Cabinet not operating	No power supply	Check fuse or power source Ensure that the general switch is on
Cabinet not maintaining temperature	1. Dirty condenser 2. Air circulation restricted 3. Check that shelves and goods are properly installed and loaded 4. Check that the cabinet is not near draughts or heat sources 5. Check that the air return or the air curtain is not blocked	Clean Remove restriction

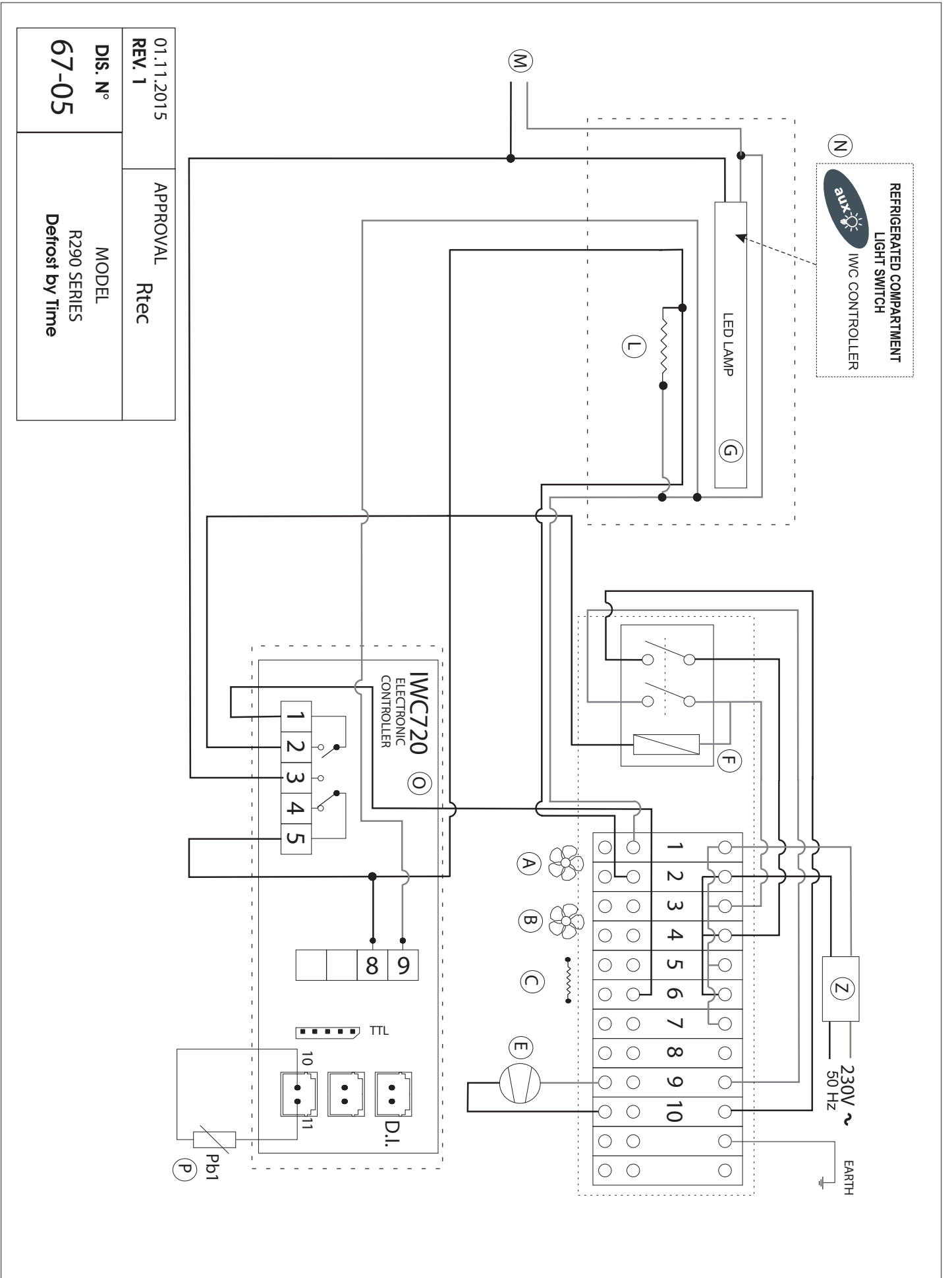

REFRIGERATED COMPARTMENT  
LIGHT SWITCH  
IWC CONTROLLER

01.11.2015 REV. 1	APPROVAL Rtec
DIS. N° 67-05	MODEL R290 SERIES Defrost by Time

01.11.2015 REV. 1	APPROV. Rtec
DIS. N° <b>69-05</b>	MODEL 2015 Series Destrot by time

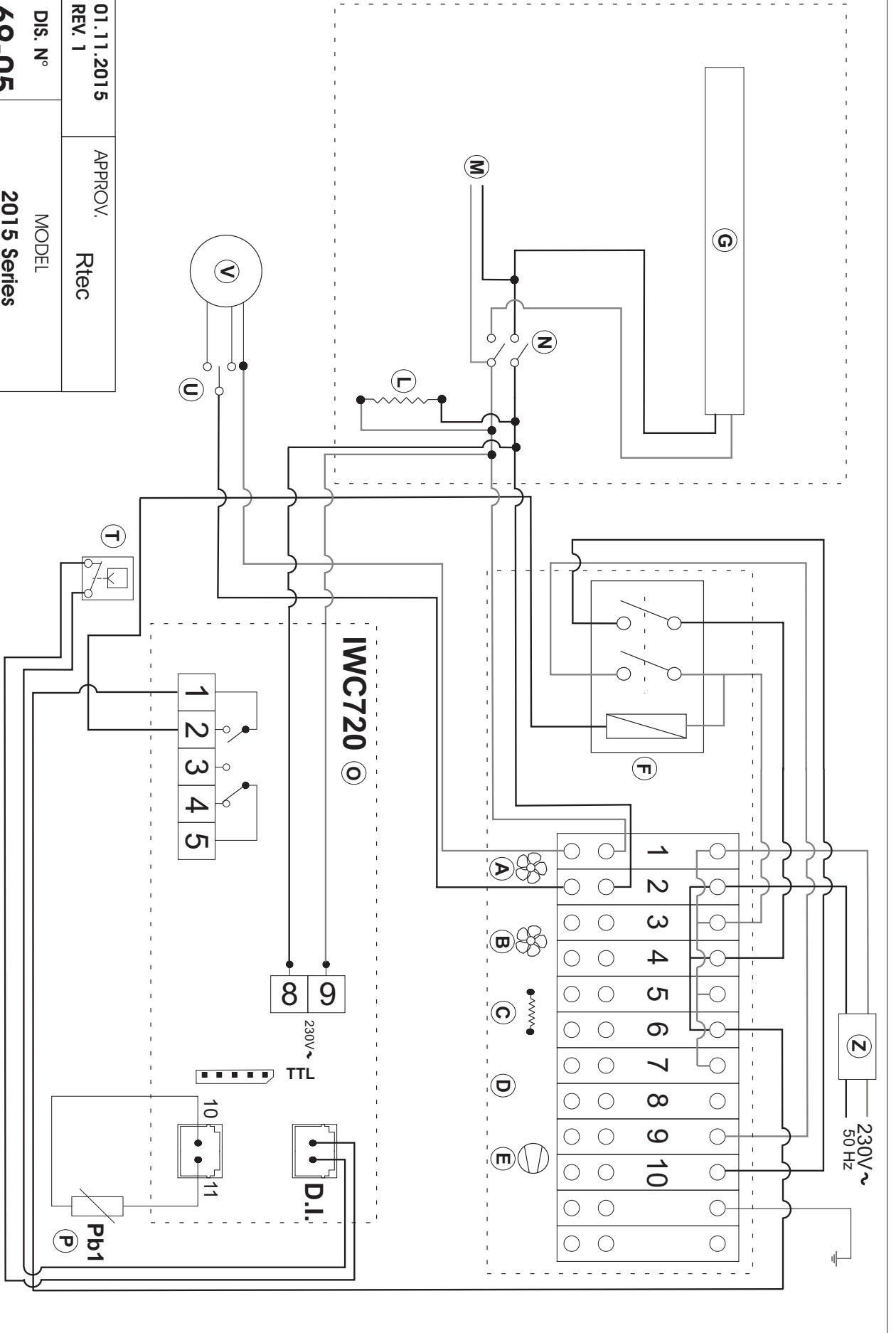

© REPRODUCTION IN WHOLE OR IN PART OF THIS DOCUMENT IS PROHIBITED UNLESS AUTHORIZED BY THE AUTHOR

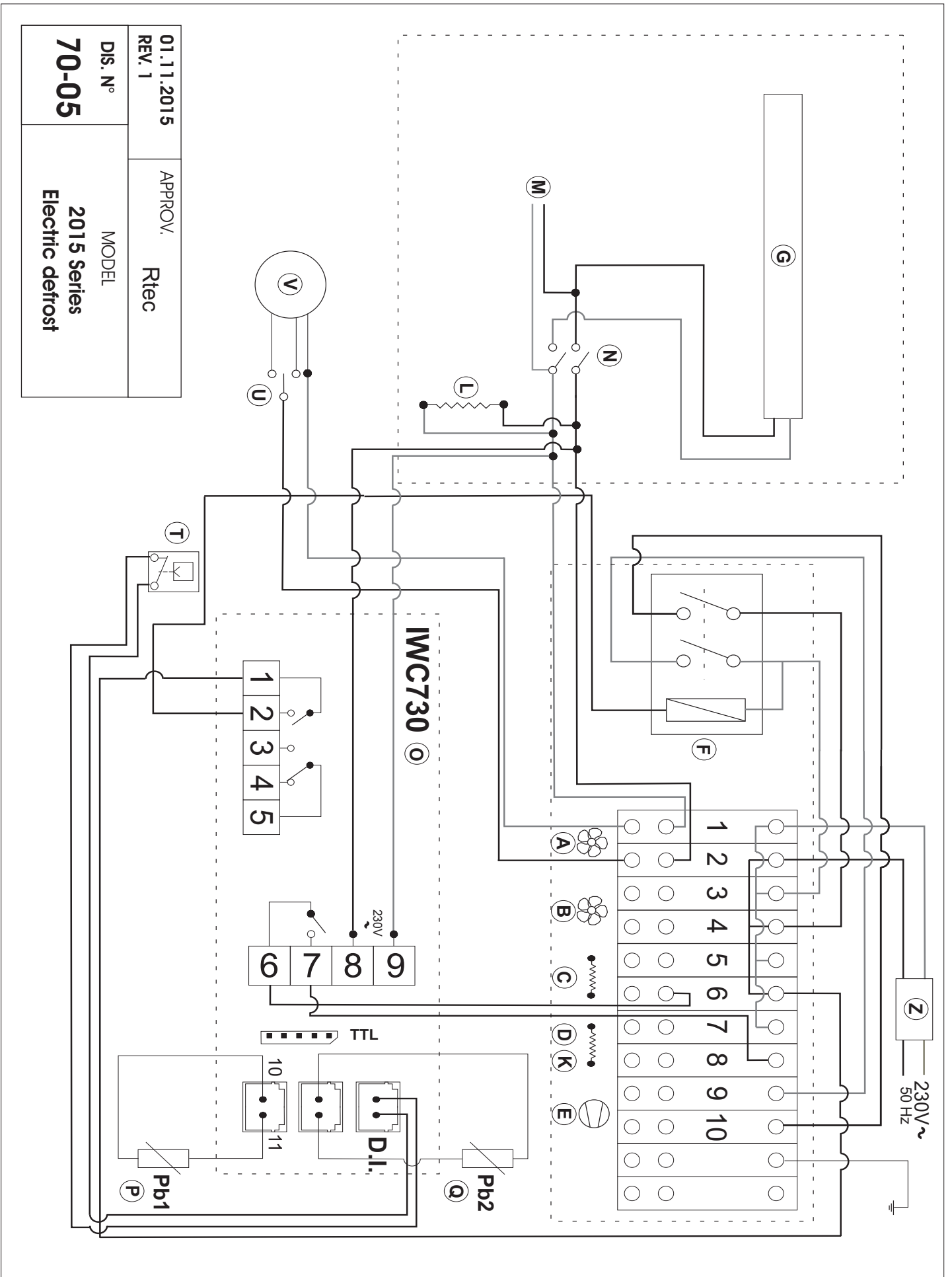

01.11.2015	APPROV.
REV. 1	Rtec
DIS. N°	MODEL
<b>70-05</b>	<b>2015 Series</b>
	<b>Electric defrost</b>

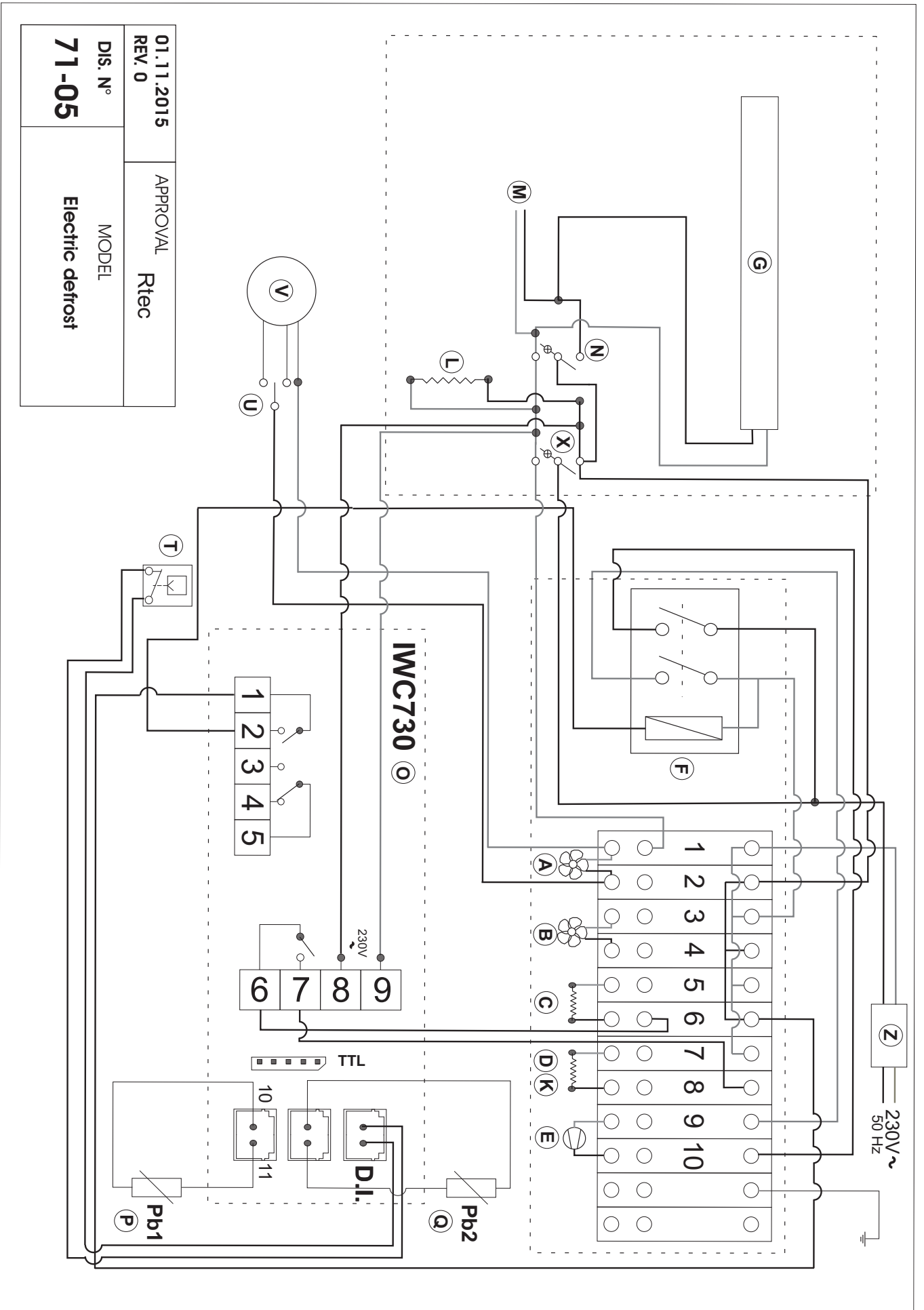

01.11.2015 REV. 0	APPROVAL Rtec
DIS. N° <b>71-05</b>	MODEL Electric defrost

© REPRODUCTION IN WHOLE OR IN PART OF THIS DOCUMENT IS PROHIBITED UNLESS AUTHORIZED BY THE AUTHOR

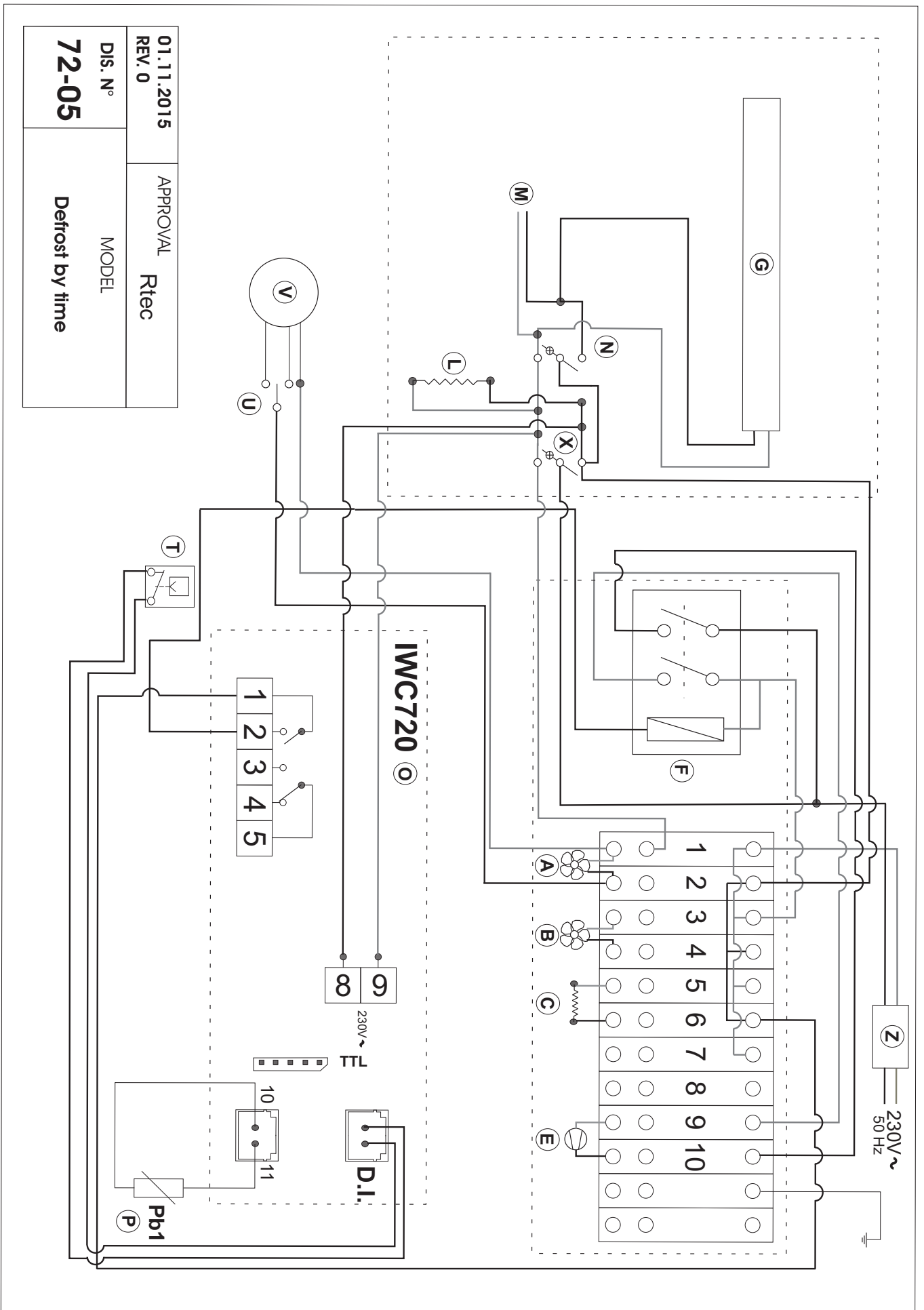

01.11.2015	APPROVAL
REV. 0	Rtec
DIS. N°	MODEL
<b>72-05</b>	<b>Defrost by time</b>

© REPRODUCTION IN WHOLE OR IN PART OF THIS DOCUMENT IS PROHIBITED UNLESS AUTHORIZED BY THE AUTHOR

- A** SELF EVAPORATING SYSTEM FAN/FANS  
(CONDENSER VENTILATOR IF: MOD. 71 x 1,  
MOD. 71, 100, 120 GREENLOGIC X 1, MOD. 100  
SCROLL X 1, MOD. 120, 150, 180 SCROLL x 2)
- B** EVAPORATOR FAN/FANS
- C** SELF EVAPORATING SYSTEM RESISTANCE  
(STANDARD ON MOD. 71 AND MOD. 71,  
100, 120 GREENLOGIC, OPTION ON OTHER  
MODELS)
- D** EVAPORATOR RESISTANCE (MT VERSION)
- E** CONDENSING UNIT
- F** MINI CONTACTOR
- G** LED LAMP
- K** THERMAL FUSE (MT VERSION)
- L** HEATING CABLE
- M** OTHER LED LAMPS (OPTION)
- N** LIGHTING SWITCH
- O** ELECTRONIC PANEL
- P** AMBIENT TEMPERATURE PROBE
- Q** EVAPORATOR PROBE (MT VERSION)
- T** MINI MANOSTAT (OPTION)
- U** SHUTTER/NIGHT BLIND MOTOR CONTROL  
SELECTOR (OPTION)
- V** SHUTTER/NIGHT BLIND MOTOR (OPTION)
- X** MAIN ELECTRICAL SWITCH (OPTION)
- Y** REFRIGERATED COMPARTMENT FANS SWITCH  
(OPTION)
- Z** ELECTRO-MAGNETIC INTERFERENCE FILTER







## Design Excellence : Cool Technology

### Williams Refrigeration

Bryggen Road  
North Lynn Industrial Estate  
King's Lynn  
Norfolk PE30 2HZ  
Sales Tel: +44 1553 817000  
Sales Fax: +44 1553 817111  
Spares Tel: +44 1553 817017  
Spares Fax: +44 1553 817020

info@williams-refrigeration.co.uk  
www.williams-refrigeration.co.uk

### Williams Silver Frost

2 rue Conventiennel Huguet  
23000 GUERET  
France  
Tel: +33 5 55 52 27 88  
Fax: +33 5 55 62 10 61  
info@williams-refrigeration.fr  
www.williams-refrigeration.fr

### Williams Dubai

603-604 Building 1B  
Dubai Design District  
PO Box 333215  
Dubai  
United Arab Emirates  
Tel: +971 4 510 8203  
sales@williams-dubai.ae

### Williams Refrigeration Australia

38-42 Gaine Road  
Dandenong South, Victoria 3175  
Australia  
Tel: +61 3 8787 4747  
Fax: +61 3 8787 4787  
sales@williamsref.com.au  
www.williams-refrigeration.com.au

### Williams Refrigeration Hong Kong

Unit C, 12/F, Roxy Industrial  
Centre,  
58 - 66 Tai Lin Pai Road, Kwai  
Chung,  
New Territories, Hong Kong  
Tel: +852 2407 5422  
Fax: +852 2407 3767  
sales@williams-hongkong.com  
www.williams-refrigeration.com.hk

[www.williams-refrigeration.com](http://www.williams-refrigeration.com)

Williams Refrigeration is a trading name of AFE Group Limited.  
Registered in England & Wales under Registered Number 3872673.  
Registered Office Address - Bryggen Road, North Lynn Industrial Estate,  
King's Lynn, Norfolk, PE30 2HZ

